

# IPA FITTINGS

## FOR VEKA DANLINE 70

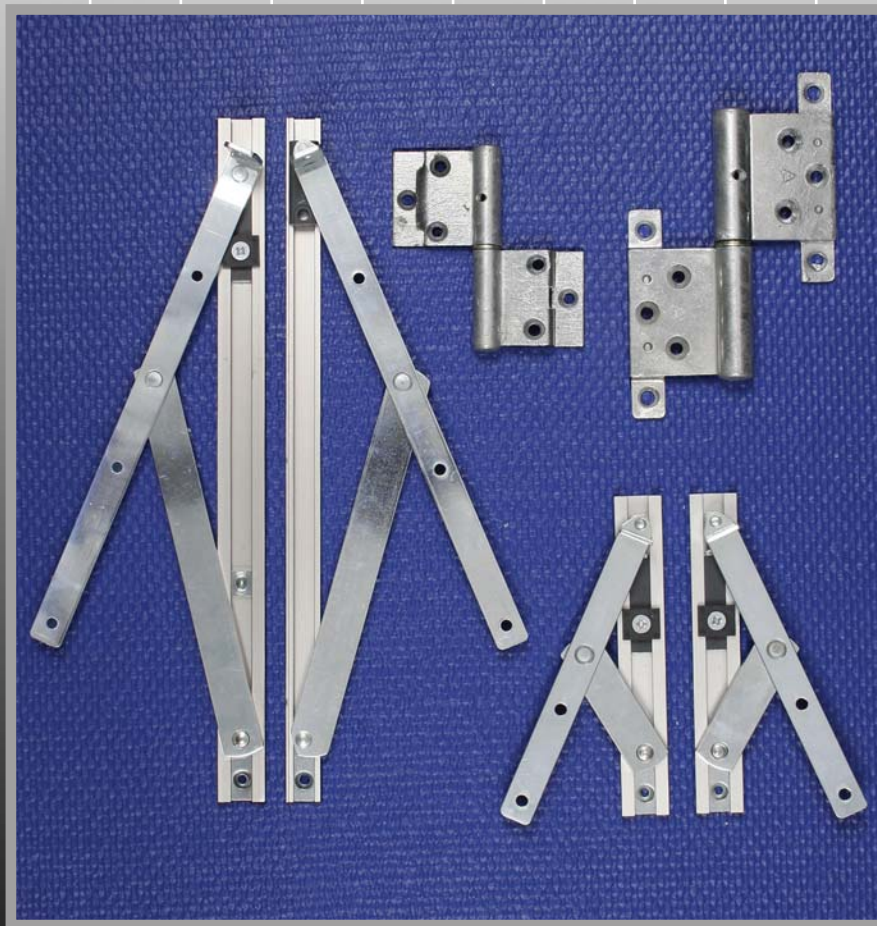

2020



**A/S J. PETERSENS BESLAGFABRIK**

JACOB PETERSENSVEJ 9, DK-9240 NIBE

TEL: (+45) 98 35 15 00







# FITTINGS FOR VEKA DANLINE 70

## Table of Contents

	<u>PAGE</u>
Profile - VEKA Danline 70	4
Suggestion - Number of Hinges	5
Suggestion - Hinge Positions	6
 <b>FITTINGS</b>	
IPA No. 61508            Doorhinge for top mouting	7
IPA No. 61574            Window hinge	8
IPA No. 61598            Door hinge	9
IPA No. 62695            Side swing window 90° with friction	11 - 12
IPA No. 62504 - 12      Top swing fitting 180°	13 - 14
IPA No. 62562            Safety Restrictor	13 - 14
IPA No. 62155            Threated plate for IPA No. 62544 - 52	13 - 14
IPA No. 62570 - 75      Canopy Stays with friction	15 - 16
IPA No. 62586 - 87+89 Adjustable Canopy Stays with friction	17 - 18
IPA No. 62588            Adjustable Canopy Stay with Adjustable Friction	19 - 20
IPA No. 62536            Safety Restrictor	21 - 22
IPA No. 62527            Friction Stay for windows	23
IPA No. 63511            Friction Stay for doors	24
IPA No. 62222            Support Fitting	25
IPA No. 63230            Guide Block	25
IPA No. 63508 - 09      Flush Bolt	25
IPA No. 21371            Casement Hook	26 - 27
IPA No. 21379            Casement Hook	26 - 27
IPA No. 21382            Hook Catch	26 - 27
IPA No. 21396            Casement Fasteners	26 - 27
IPA No. 23701 - 10      Espagnolettes	28 - 29
IPA No. 23269            Receiver	28 - 29
IPA No. 23228 - 29      Handles	28 - 29
Lubrication Instructions	30 - 31



# VEKA DANLINE 70 PROFILE

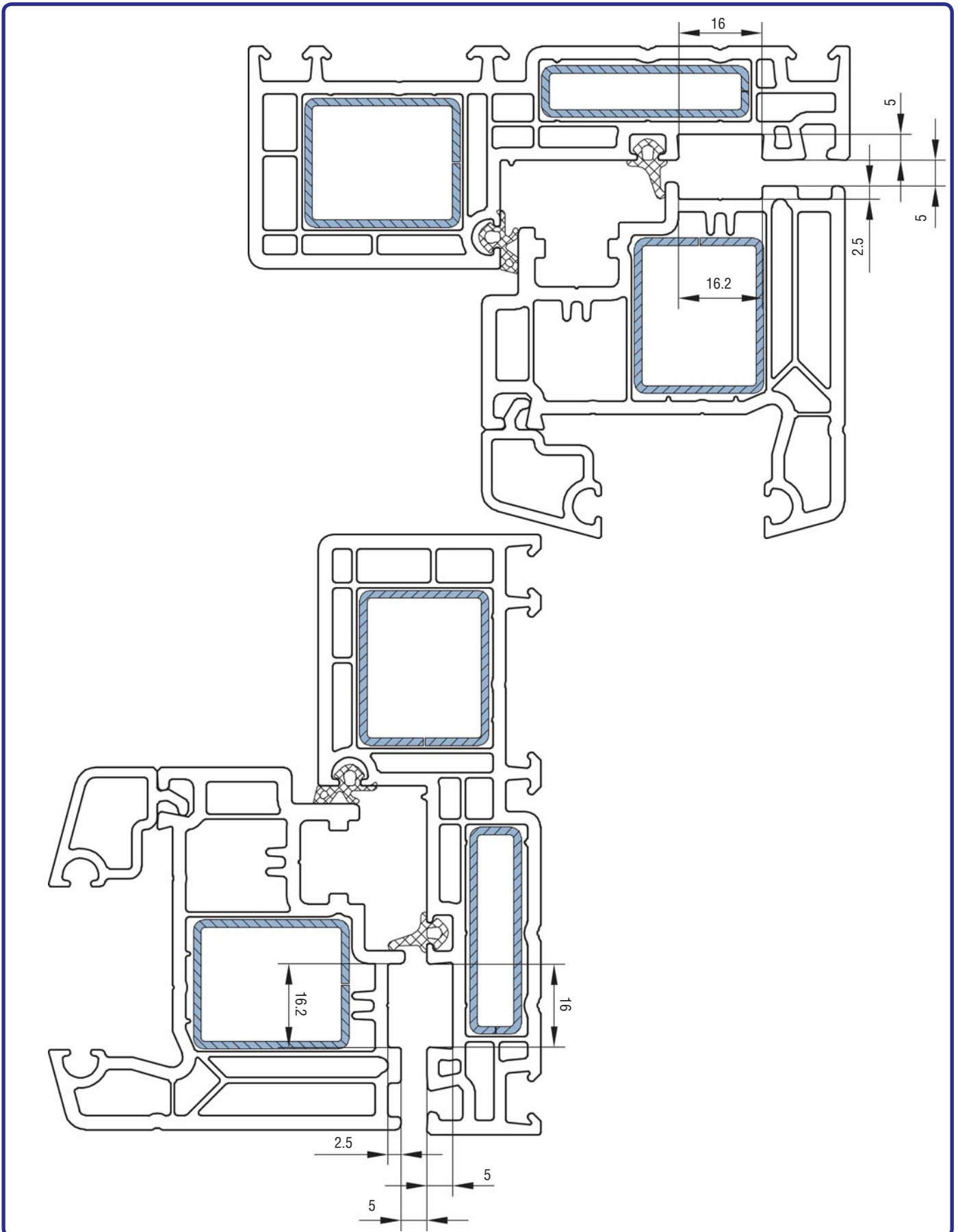



## SUGGESTION - NUMBER OF HINGES

The charts below show the number of hinges, we suggest to use on different sizes of windows and doors. The charts shall ONLY be considered as a guidance, as the number of hinges also will depend on the use and weight of the window/door. If the window/door is mounted in a public building with many users (Schools, Railway Stations etc.) then more or even larger hinges are recommended.

Also we suggest to use a support fitting whenever possible.

**WINDOW HINGES:** Valid for the window hinges shown in this catalogue.

All window hinges meets the requirements of class 9 (60 Kgs.) in accordance with DS/EN 1935. The numbers in brackets are number of hinges in windows with 3-layer glass.

Width \ Height	< 500	501 - 600	601 - 700	701 - 800
1401 - 1500	2 (3)	3 (3)	3 (3)	3 (4)
1301 - 1400	2 (3)	3 (3)	3 (3)	3 (4)
1201 - 1300	2 (3)	3 (3)	3 (3)	3 (4)
1101 - 1200	2 (3)	3 (3)	3 (3)	3 (4)
1001 - 1100	2 (3)	3 (3)	3 (3)	3 (3)
901 - 1000	2 (2)	2 (2)	2 (2)	3 (3)
801 - 900	2 (2)	2 (2)	2 (2)	3 (3)
701 - 800	2 (2)	2 (2)	2 (2)	3 (3)
601 - 700	2 (2)	2 (2)	2 (2)	
501 - 600	2 (2)	2 (2)		
< 500	2 (2)			

**DOORHINGES:** Valid for door hinges shown in this catalogue.

All door hinges with steel pin meets the requirements of class 13 (120 Kgs.) in accordance with DS/EN 1935. The same hinges with brass pin meets the requirements of class 11 (80 Kgs.) in accordance with DS/EN 1935

Width \ Height	< 700	701 - 800	801 - 900	901 - 1000	1001 - 1100
2501 - 2600	5	5	5		
2401 - 2500	5	5	5	5	
2301 - 2400	4	4	4	5	5
2201 - 2300	4	4	4	4	5
2101 - 2200	3	3	3	4	4
2001 - 2100	3	3	3	3	4
< 2000	3	3	3	3	4



## SUGGESTION - HINGE POSITIONS

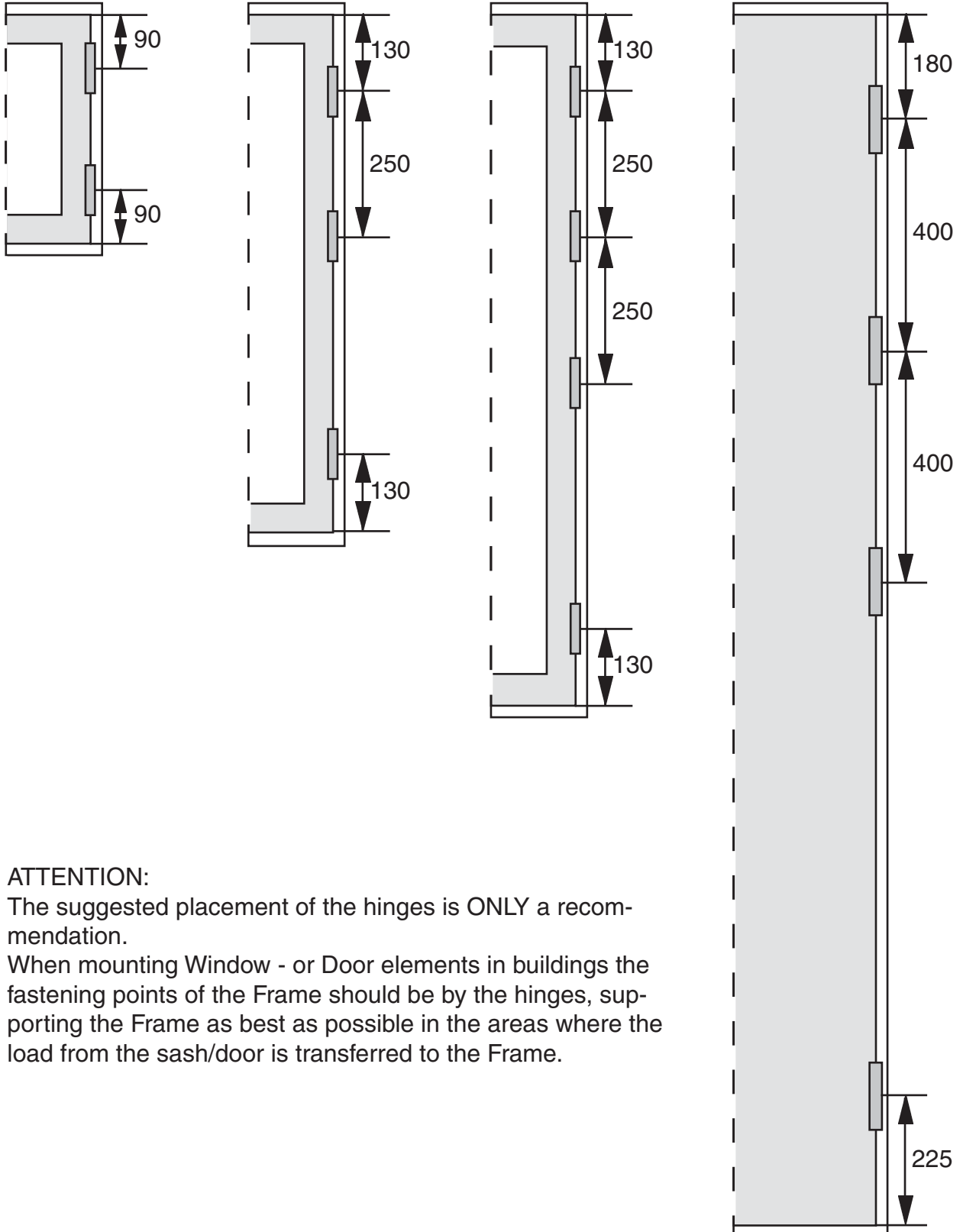

### ATTENTION:

The suggested placement of the hinges is ONLY a recommendation.

When mounting Window - or Door elements in buildings the fastening points of the Frame should be by the hinges, supporting the Frame as best as possible in the areas where the load from the sash/door is transferred to the Frame.



# DOORHINGE FOR TOP MOUNTING IPA No. 61508

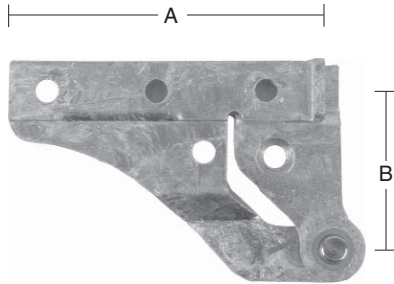
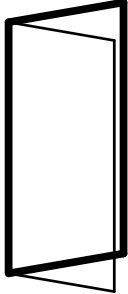

**61508**  
LEFT

ORDERING NO.										
IPA NO.	MATERIAL		SURFACE		STANDARD PACKING IN BOXES OF 10 PCS.	A MM	B MM	MATERIAL MM	SCREW	APPROX. WEIGHT KGS / PC.
	STEEL	LEFT	RIGHT	GALVANIZED						
<b>61508</b>	<b>1</b>	<b>7</b>	<b>8</b>	<b>87</b>	<b>1</b>	83	41,5	2,5	4,0	0,11



## IPA No. 61508 FITTING INSTRUCTIONS

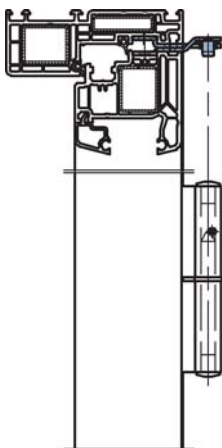

FIG. 1

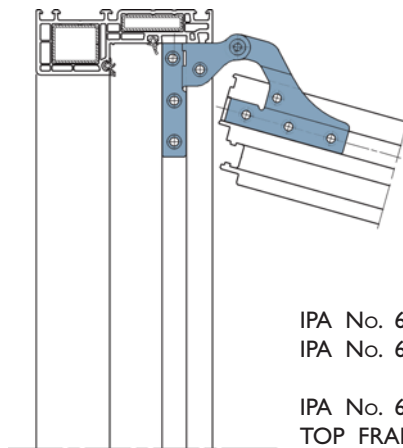

FIG. 2

IPA No. 61508 IS TO BE USED TOGETHER WITH DOOR HINGE  
IPA No. 61598

IPA No. 61508 IS MOUNTED ON HINGE SIDE ON TOP SASH AND  
TOP FRAME AS SHOWN ON FIG. 1 AND FIG. 2

#### MAINTENANCE:

TEST THE OPERATION FROM TIME TO TIME. WHEN FITTING - GREASE THE PIVOT/MOVABLE METAL PARTS OF THE MECHANISM WHILE ACTIVATING REPEATEDLY. HEREAFTER GREASE MINIMUM TWICE A YEAR. SEE ALSO INSTRUCTIONS ON PAGE 30 - 31.



# WINDOW HINGE

IPA No. 61574

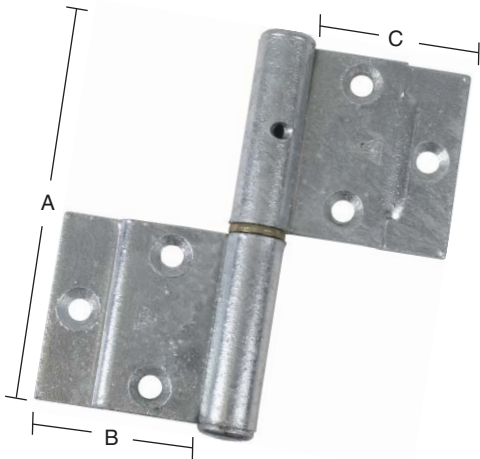
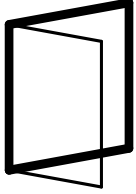

IPA NO.		MATERIAL		SURFACE		STANDARD PACKING IN BOXES OF 100 PCS.	A MM	B MM	C MM	MATERIAL MM	PIN MM	SCREW	APPROX. WEIGHT KGS / PC.	
		STEEL FIXED STEEL PIN	STEEL FIXED BRASS PIN	SAUARE EDGES LEFT	SAUARE EDGES RIGHT									ELECTROPLATED/GREY
61574	2	-	3	4	64	87	2	90	38,5	38,5	2,5	8	4,0	0,17
	-	3	3	4	-	87	2							



IPA No. 61574

# FITTING INSTRUCTIONS

PROFILE - VEKA DANLINE 70

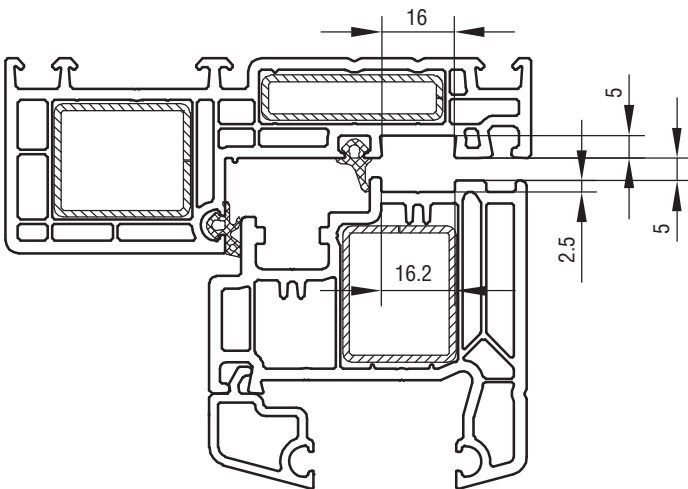

FIG. 1

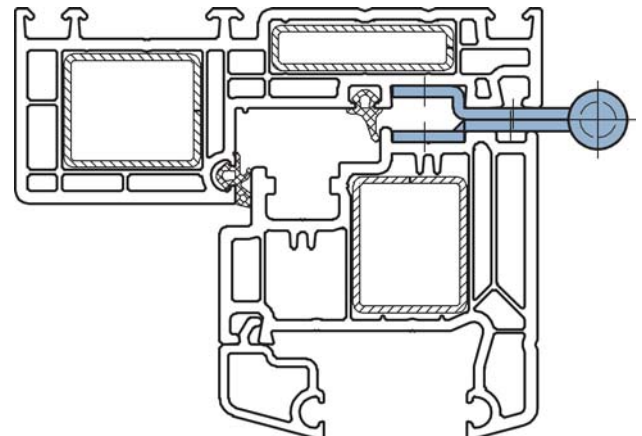

FIG. 2

USE SCREW NO. 4.0.

**MAINTENANCE:**

TEST THE OPERATION FROM TIME TO TIME. WHEN FITTING - GREASE THE PIVOT/MOVABLE METAL PARTS OF THE MECHANISM WHILE ACTIVATING REPEATEDLY. HEREAFTER GREASE MINIMUM TWICE A YEAR. SEE ALSO INSTRUCTIONS ON PAGE 30 - 31.





# DOOR HINGE

## IPA No. 61598

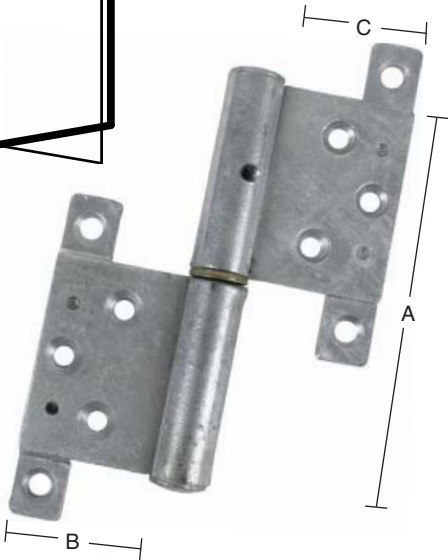
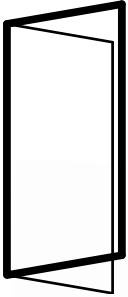

ORDERING NO.								A MM	B MM	C MM	MATERIAL MM	PIN MM	SCREW	APPROX. WEIGHT KGS / PC.
IPA NO.	MATERIAL		SAJARE EDGES LEFT	SAJARE EDGES RIGHT	SURFACE		STANDARD PACKING IN BOXES OF 50 PCS.							
	STEEL FIXED STEEL PIN	STEEL FIXED BRASS PIN			ELECTROPLATED/GREY	GALVANIZED								
61598	2	-	3	4	64	87	2	120	41	41	4,0	9,5	5,0	0,43
	-	3	3	4	-	87	2							



# IPA No. 61598

## FITTING INSTRUCTIONS

PROFIL - VEKA DANLINE 70

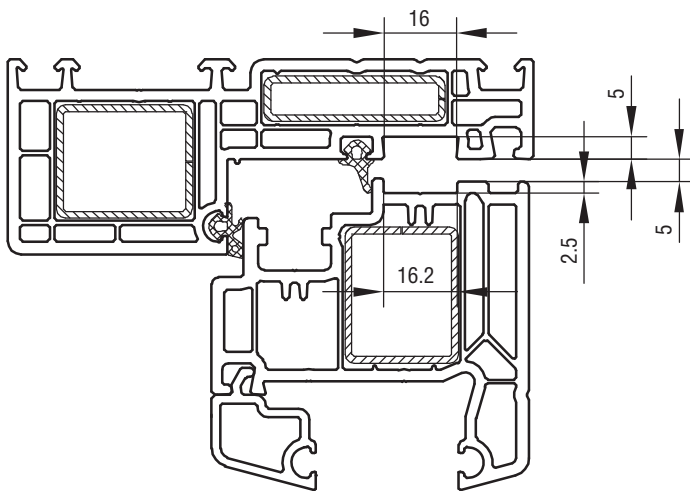

FIG. 1

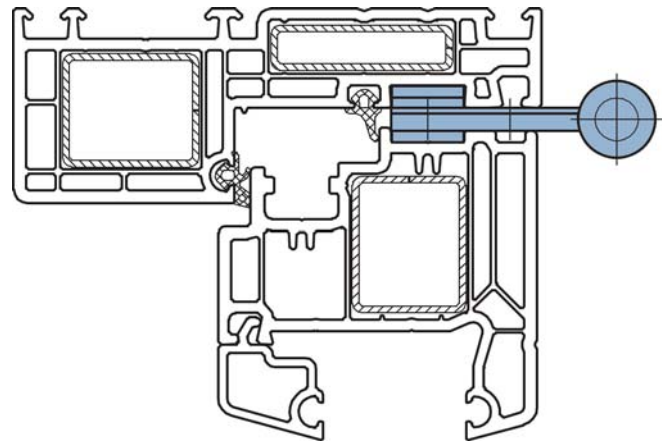

FIG. 2

USE SCREW NO. 4.0.

**MAINTENANCE:**

TEST THE OPERATION FROM TIME TO TIME. WHEN FITTING - GREASE THE PIVOT/MOVABLE METAL PARTS OF THE MECHANISM WHILE ACTIVATING REPEATEDLY. HEREAFTER GREASE MINIMUM TWICE A YEAR. SEE ALSO INSTRUCTIONS ON PAGE 30 - 31.



A large, empty rectangular box with a blue border, intended for writing or drawing.



# SIDE SWING WINDOW 90° WITH FRICTION IPA No. 62695

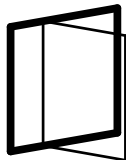

ORDERING NO.										
IPA NO.	MATERIAL		SURFACE			A MM	B MM	C MM	SCREW	APPROX. WEIGHT KG / SET
	STEEL	LEFT	RIGHT	ELECTROPLATED	STANDARD PACKING IN BOXES OF 5 SETS					
<b>62695</b>	<b>1</b>	<b>7</b>	<b>8</b>	<b>21</b>	<b>1</b>	19	17.5	325	4.0	0.44

- ADJUSTABLE FRICTION
- CONVENIENT FOR CLEANING
- SWINGS 90°
- OPENS CLEAR FROM CURTAINS  
AND WINDOW FRAME
- MAX. VENTILATION
- CONCEALED FITTINGS
- ANODIZED ALUMINIUM RAILS

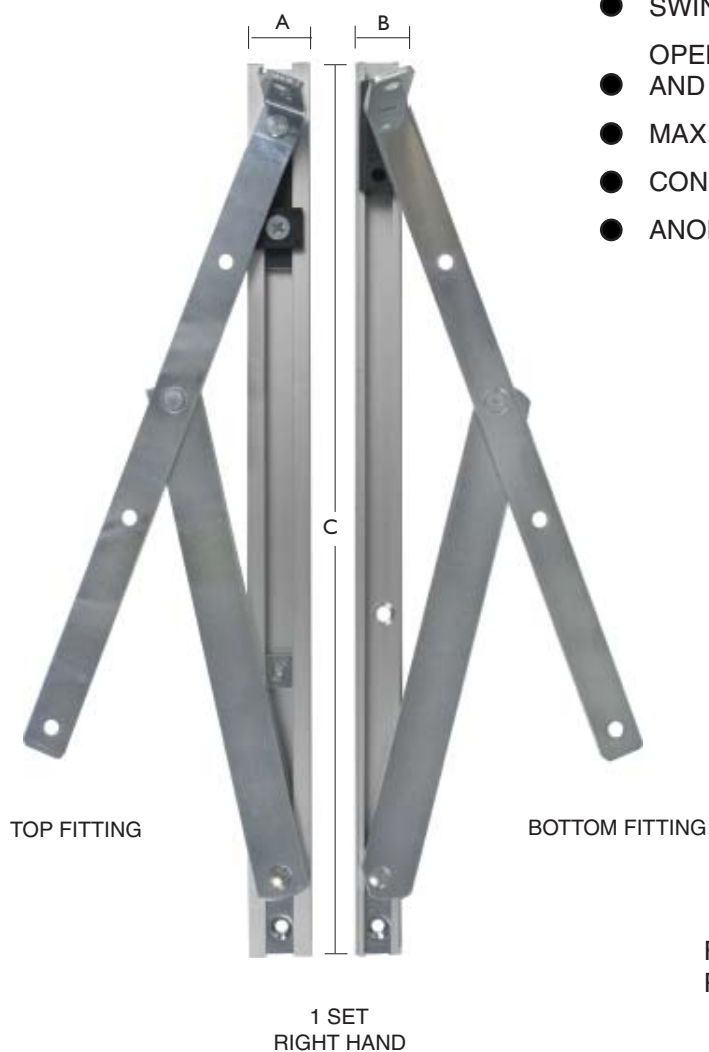

FIRE-ESCAPE OPENING:  
PLEASE SEE [WWW.IPAFITTINGS.COM/RESCUE](http://WWW.IPAFITTINGS.COM/RESCUE)



# IPA No. 62695 FITTING INSTRUCTIONS

PROFILE - VEKA DANLINE 70:

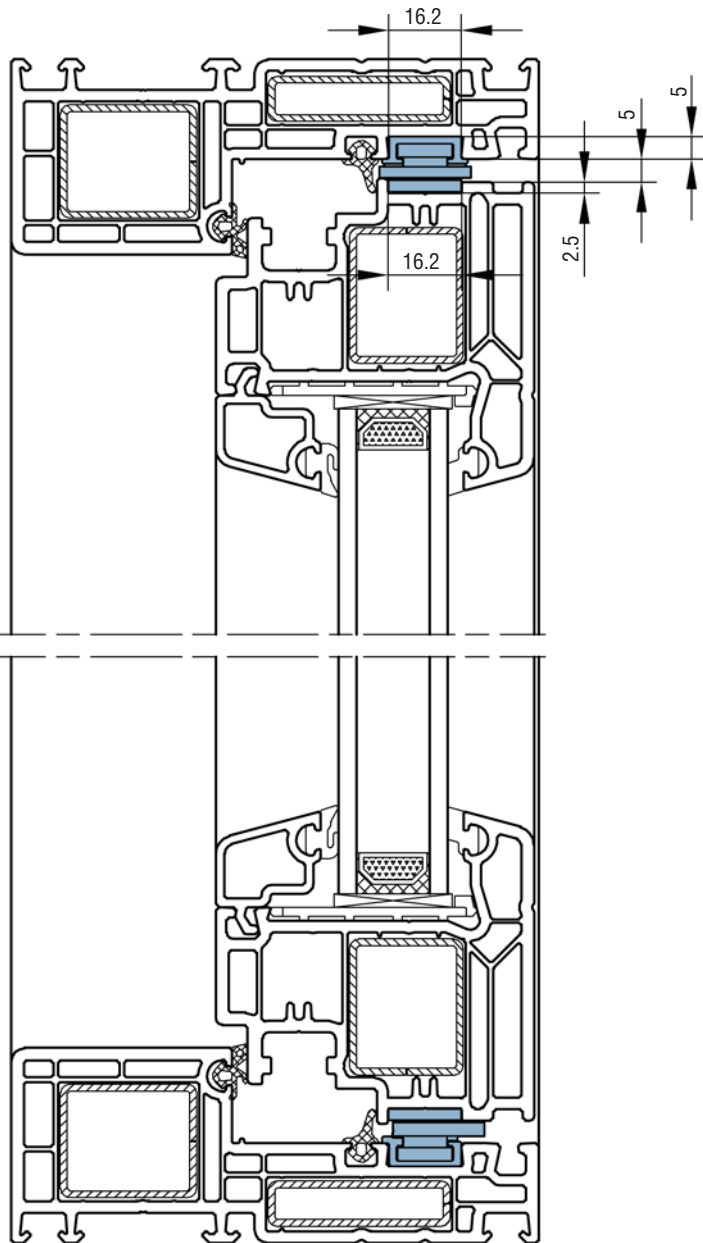

FIG. 1  
VERTICAL PLAN

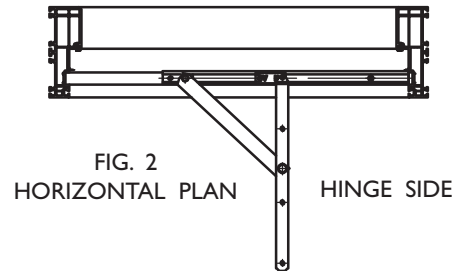

FIG. 2  
HORIZONTAL PLAN HINGE SIDE

FITTING SHOWN ON FRAME CILL  
RIGHT HAND ILLUSTRATION

IPA NO.	62695
MAX. WEIGHT OF SASH KGS	40
MIN. WIDTH OF SASH MM	315
MAX. WIDTH OF SASH MM	820
USE SCREW NO.	4.0

FIG. 3

REG. TALL AND NARROW WINDOWS:  
PLEASE NOTICE THAT ON TALL AND NARROW SASHES THE FLEXIBILITY OF THE MATERIAL MAY EFFECT HE MOVEMENT OF THE FITTING'S SLIDING ELEMENTS IN TOP AND BOTTOM. IT CAN THEREFOR BE NECESSARY TO USE BOTH HANDS TO STABILIZE THE SASH WHEN OPENING THE WINDOW. THESE FITTINGS ARE NOT SUITABLE FOR DOOR HEIGHT WINDOWS.

#### FITTING:

1. THE FITTING SHOULD BE POSITIONED IN THE GROOVES AT HEAD AND CILL OF FRAME AND SCREWED ON (FIGURE 1 AND 2).
2. NOW PUSH THE WINDOW SASH INTO POSITION BY SASH SLOTS AND FASTEN THE SCREWS.
3. THE FRICTION CAN BE ADJUSTED ON THE TOP FITTING. IF A LARGER OPENING IS WANTED THEN JUST MOVE THE ADJUSTABLE STOP FITTING IN THE TOP FRAME ALUMINIUM RAIL.

#### MAINTENANCE:

THE FITTINGS ARE NOT TO BE PAINTED. TEST THE OPERATION FROM TIME TO TIME. WHEN FITTING - LUBRICATE THE PIVOT/MOVABLE METAL PARTS OF THE MECHANISM WHILE ACTIVATING REPEATEDLY. HEREAFTER LUBRICATE MINIMUM TWICE A YEAR. DO NOT LUBRICATE THE ALUMINIUM RAILS. SEE ALSO INSTRUCTIONS ON PAGE 30 - 31.



# TOP SWING FITTING

IPA No.s 62504-12, IPA No. 62562 & IPA No. 62155

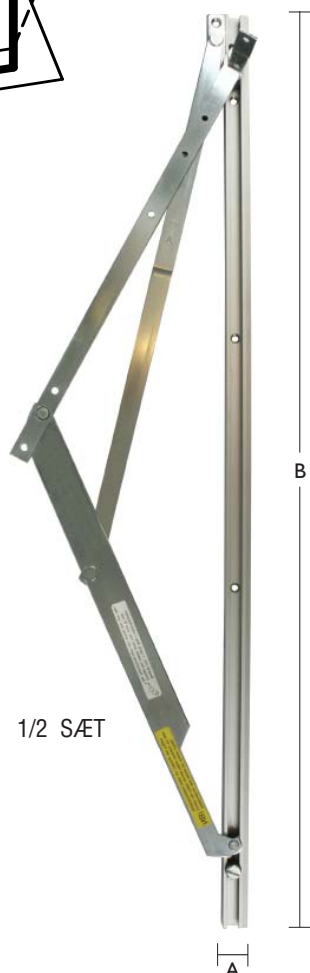
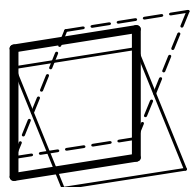

1/2 SÆT

ORDERING NO.										
IPA NO.	MATERIAL		SURFACE		STANDARD PACKING OF 1 SET PER CARTON	A MM	B MM	INNER FRAME MM	SCREW	APPROX. WEIGHT KGS / SET
	STEEL	W/O SPECIFICATION	ELECTROPLATED							
62504	1	0	21	1	18	544	544-643	4,0	1,08	
62505	1	0	21	1	18	644	644-743	4,0	1,26	
62506	1	0	21	1	18	744	744-843	4,0	1,44	
62507	1	0	21	1	18	844	844-943	4,0	1,62	
62508	1	0	21	1	18	944	944-1043	4,0	1,80	
62509	1	0	21	1	18	1044	1044-1143	4,0	1,98	
62510	1	0	21	1	18	1144	1144-1243	4,0	2,16	
62511	1	0	21	1	18	1244	1244-1343	4,0	2,34	
62512	1	0	21	1	18	1344	1344-1443	4,0	2,52	

- CONSEALED FITTING
- ADJUSTABLE FRICTION
- FULLY REVERSIBLE 170°
- OPENS CLEAR OF CURTAINS AND WINDOW FRAME
- ANODIZED ALUMINIUM RAILS

FIRE-ESCAPE OPENING:  
PLEASE SEE [WWW.IPAFITTINGS.COM/RESCUE](http://WWW.IPAFITTINGS.COM/RESCUE)



SAFETY RESTRICTOR  
IPA NO. 62562

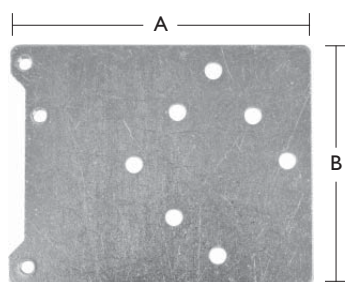

THREADED PLATE  
IPA NO. 62155

ORDERING NO.								
IPA NO.	MATERIAL		SURFACE		STANDARD PACKING IN BOXES OF 20 PCS.	A MM	SCREW	APPROX. WEIGHT KGS / PC.
	STEEL	LEFT	ELECTROPLATED					
62562	1	7	21	1	170	3,5	0,08	

ORDERING NO.									
IPA NO.	MATERIAL		SURFACE		STANDARD PACKING IN BOXES OF 25 PCS.	A MM	B MM	SCREW	APPROX. WEIGHT KGS / PC.
	STEEL	W/O SPECIFICATION	ELECTROPLATED						
62155	1	0	21	1	80	70	4,0	0,12	



# IPA No.s 62504-12 & IPA No. 62562 FITTING INSTRUCTIONS

IMPORTANT: THE SIDE FRAMES MUST BE STRAIGHT TO THE EFFECT THAT THE DISTANCE BETWEEN THE SIDE FRAMES (SLIDING RAILS) IS EXACTLY THE SAME FOR ANY HEIGHT OF THE FRAME. THIS IS IMPERATIVE FOR THE SLIDES TO TRAVEL FREELY IN THEIR ALUMINIUM RAILS.

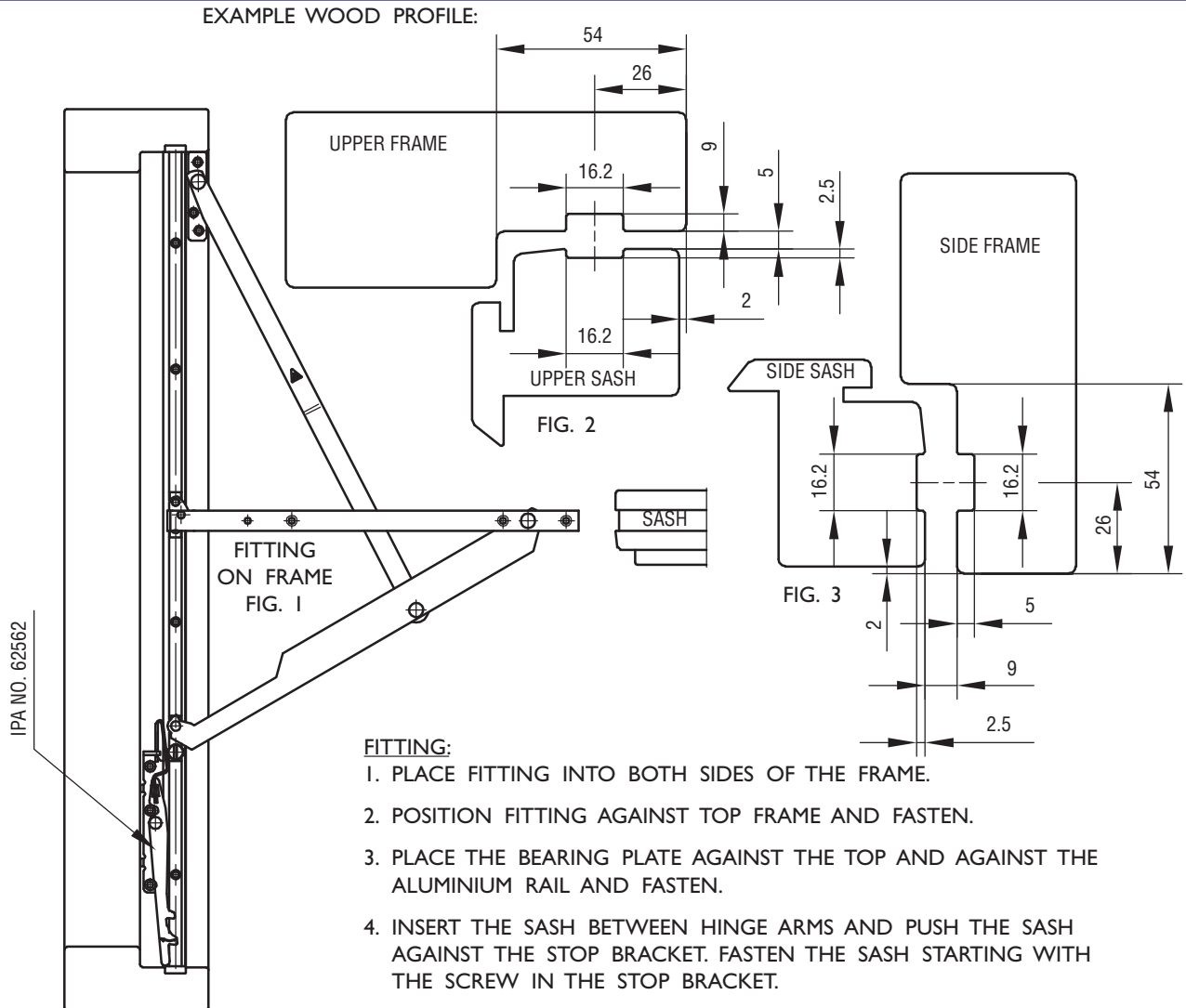

#### FITTING:

1. PLACE FITTING INTO BOTH SIDES OF THE FRAME.
2. POSITION FITTING AGAINST TOP FRAME AND FASTEN.
3. PLACE THE BEARING PLATE AGAINST THE TOP AND AGAINST THE ALUMINIUM RAIL AND FASTEN.
4. INSERT THE SASH BETWEEN HINGE ARMS AND PUSH THE SASH AGAINST THE STOP BRACKET. FASTEN THE SASH STARTING WITH THE SCREW IN THE STOP BRACKET.
5. THE SASH CAN BE OPENED TO ANY ANGLE. WITH LARGE OPENING ANGLE A LIGHT FRICTION CAN BE OBTAINED BY MEANS OF THE FRICTION SCREWS IN THE SIDES. THE FRICTION HAS TO BE THE SAME ON BOTH SIDES. PLEASE NOTE THAT THE SASH IS NOT SECURED FOR HEAVY WINDS AND OTHER HEAVY INFLUENCE.
6. FIT THE RESTRICTOR IPA NO. 62562 ON THE LEFT SIDE, SEE FIG. 1.

USE SCREW NO. 4.0.

#### OPERATION INSTRUCTIONS:

1. OPEN THE WINDOW - THE RESTRICTOR WILL AUTOMATICALLY RESTRICT THE WINDOW.
2. PULL THE SASH 20 MM - PRESS THE RESTRICTOR IN THE DIRECTION OF THE ARROW AND OPEN THE WINDOW.
3. WHEN THE WINDOW IS REVERSED FOR CLEANING, THE RESTRICTOR WILL LOCK AUTOMATICALLY. DISENGAGE AS MENTIONED IN POINT 2.

#### MAINTENANCE:

THE FITTINGS ARE NOT TO BE PAINTED. WHEN FITTING - LUBRICATE THE PIVOT/MOVABLE METAL PARTS OF THE MECHANISM WHILE ACTIVATING REPEATEDLY. HERAFTER LIBRICATE MINIMUM TWICE A YEAR. DO NOT GREASE THE ALUMINIUM RAILS. TEST THE OPERATION FROM TIME TO TIME. SEE ALSO INSTRUCTIONS ON PAGE 41 - 42.

IPA NO.	FITTING LENGTH MM	MAX. WEIGHT KGS.
62504	544	45
62505	644	45
62506	744	45
62507	844	45
62508	944	60
62509	1044	60
62510	1144	60
62511	1244	60
62512	1344	60

**USE THE LARGEST POSSIBLE FITTING**

**ATTENTION: MAX. WIDTH = HEIGHT + 300 MM, HOWEVER MAX. 1600 MM.**



# CANOPY STAYS WITH FRICTION

## IPA No. 62570-75

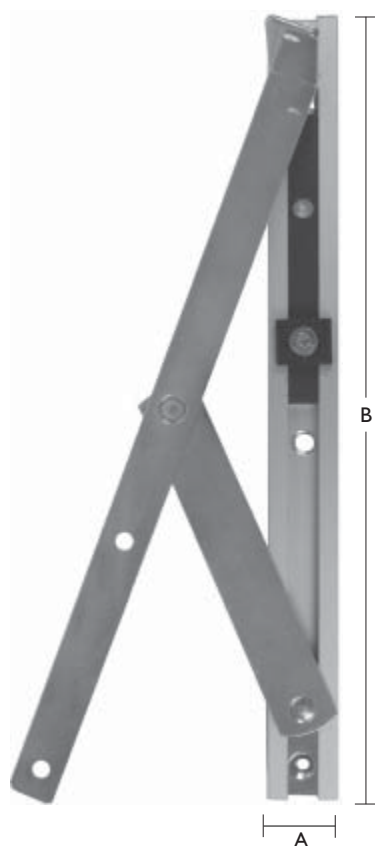
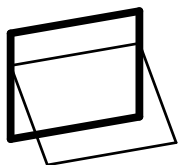

1/2 SET

ORDERING NO.									
IPA NO.	MATERIAL	W/O SPECIFICATION	SURFACE	STANDARD PACKING IN BOXES OF 5 SETS.	INDUSTRY PACKING IN BOXES OF 25 SETS.	A MM	B MM	SCREW	APPROX. WEIGHT KGS / SET
	STEEL		ELECTROPLATED						
62570	1	0	21	-	2	19	255	4.0	0.44
62573	1	0	21	-	2	19	445	4.0	0.64
62574	1	0	21	1	-	19	703	4.0	1.02
62575	1	0	21	1	-	19	152	4.0	0.26

- CONCEALED FITTINGS
- ADJUSTABLE FRICTION
- ANODIZED ALUMINIUM RAILS
- THE MOVEMENT GEOMETRY ENSURES MAXIMUM SEALING

FIRE-ESCAPE OPENING:  
PLEASE SEE [WWW.IPAFITTINGS.COM/RESCUE](http://WWW.IPAFITTINGS.COM/RESCUE)

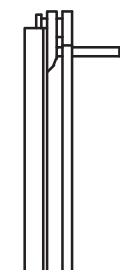

62575

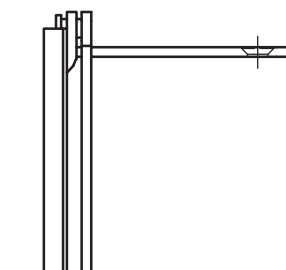

62570-74



# IPA No. 62570-75 FITTING INSTRUCTIONS

PROFIL - VEKA DANLINE 70 → 16

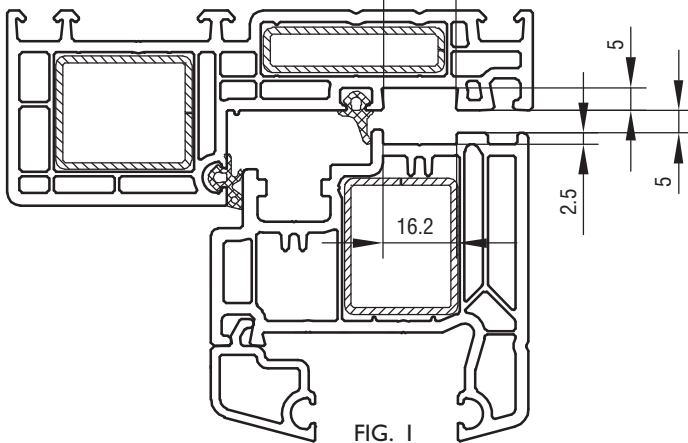

FIG. 1

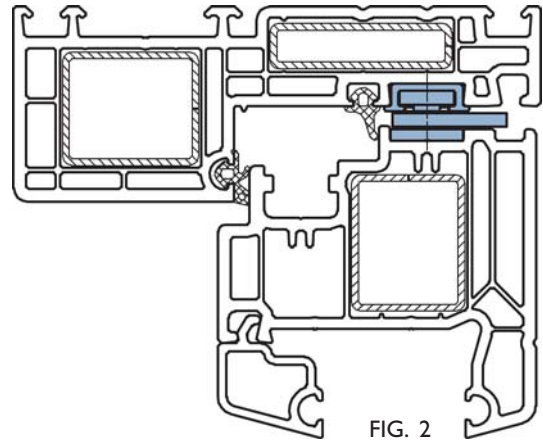

FIG. 2

IPA NO.	62570	62573	62574	62575
MAX. SASH WEIGHT KG	40	50	70	20
MAX. INSIDE FRAME HEIGHT MM	844	1344	1544	310
USE SCREW NO.	4.0	4.0	4.0	4.0

**ESPECIALLY FOR IPA NO. 62573 OG 62574:**  
THE SCREW IN THE TOP OF THE FRICTION ELEMENT IS ONLY TO ENSURE THAT THE GLIDING ELEMENT BELOW MOVES CORRECTLY IN THE ALUMINIUM RAIL. THEREFORE THIS SCREW MUST NOT BE ADJUSTED.

## FITTING:

- CLOSE THE FITTING AND PLACE IT IN THE GROOVE OF THE SIDE FRAME.  
PLACE THE FITTING AGAINST THE TOP FRAME.  
PLACE AND FASTEN THE SCREW IN THE BOTTOM HOLE OF THE FITTING.  
62573: FASTEN THE STOP PLATE THROUGH THE UPPER SCREW HOLE IN THE STOP PLATE AND THROUGH THE UPPER SCREW HOLE IN THE ALURAIL. THIS ENABLES MAX. FIRE ESCAPE OPENING. USE LOWER SCREW HOLE IN STOP PLATE TO ACHIEVE A MAX. SASH LOAD OF 60 KGS. IF LOWER SCREW HOLE IS USED THE FIRE ESCAPE OPENING WILL BE REDUCED.  
62574: ALWAYS USE THE UPPER SCREW HOLE IN THE ALURAIL FOR FASTENING THE STOP PLATE. USE THE UPPER SCREW HOLE IN STOP PLATE FOR MAX. FIRE ESCAPE OPENING. USE THE MIDDLE SCREW HOLE IN THE STOP PLATE TO ACHIEVE A MAX. SASH LOAD OF 85 KGS.  
USE THE LOWER SCREW HOLE IN THE STOP PLATE TO ACHIEVE A MAX. SASH LOAD OF 100 KGS.  
IF MIDDLE OR LOWER SCREW HOLES IN STOP PLATE ARE USED THE FIRE ESCAPE OPENING WILL BE REDUCED.
- PUSH THE SASH INTO ITS PLACE BY INSERTING IT BETWEEN THE HINGE ARMS, GUIDED BY THE GROOVES IN THE SASH, UNTIL THE SASH HITS THE STOPS OF THE FITTING. THESE STOPS WILL GUARANTEE A 5 MM GAB BETWEEN FRAME AND SASH. FASTEN THE FITTING STARTING WITH THE SCREW IN THE STOP BRACKET (IPA NO. 62570-74).
- NOW THE FRICTION MAY BE ADJUSTED BY MEANS OF THE SCREWS IN THE SLIDES. THE BEST RESULT FOR THE WINDOW MOVEMENT IS ACHIEVED BY EQUAL FRICTION IN EITHER SIDE.

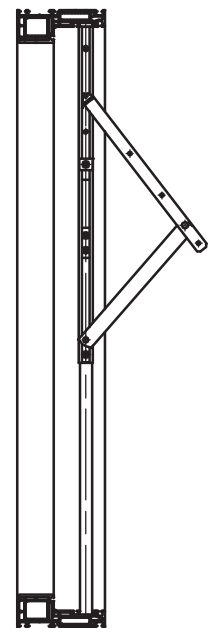

FIG. 3

## OBS! RE. IPA NO. 62573:

FOR BIG WINDOWS (>1200 MM) WITH 3-LAYER GLASS AND NO REQUIREMENTS FOR EGRESS OPENINGS THE USE OF IPA NO. 62574 IS RECOMMENDED, AS THE VENTILATION POSITION OTHERWISE MAY BE DIFFICULT TO ACHIEVE BECAUSE OF THE OPENING GEOMETRY OF THE GEARS.

## MAINTENANCE:

THE FITTINGS ARE NOT TO BE PAINTED. TEST THE OPERATION FROM TIME TO TIME. WHEN FITTING - LUBRICATE THE PIVOT/MOVABLE METAL PARTS OF THE MECHANISM WHILE ACTIVATING REPEATEDLY. HEREAFTER LUBRICATE MINIMUM TWICE A YEAR. DO NOT LUBRICATE THE ALUMINIUM RAILS. SEE ALSO INSTRUCTIONS ON PAGE 30 - 31.





# ADJUSTABLE CANOPY STAYS WITH FRICTION

## IPA No. 62586-87 & 89

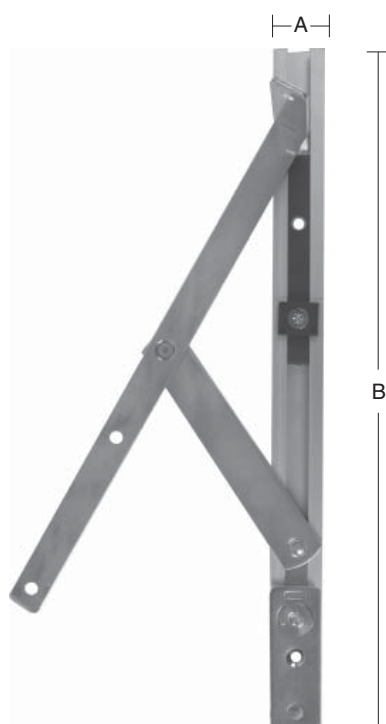
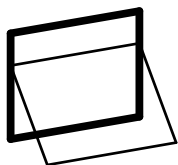

1/2 SET

ORDERING NO.								
IPA NO.	MATERIAL	W/O SPECIFICATION	SURFACE	INDUSTRY PACKING IN BOXES OF 25 SETS.	A MM	B MM	SCREW	APPROX. WEIGHT KGS / SET
	STEEL		ELECTROPLATED					
62586	1	0	21	2	19	306	4,0	0,53
62587	1	0	21	2	19	496	4,0	0,74
62589	1	0	21	2	19	755	4,0	1,15

- VERTICALLY ADJUSTABLE  $\pm 1.5$  MM
- CONCEALED FITTINGS
- ADJUSTABLE FRICTION
- ANODIZED ALUMINIUM RAILS
- THE MOVEMENT GEOMETRY ENSURES MAXIMUM SEALING

FIRE-ESCAPE OPENING:  
PLEASE SEE [WWW.IPAFITTINGS.COM/RESCUE](http://WWW.IPAFITTINGS.COM/RESCUE)

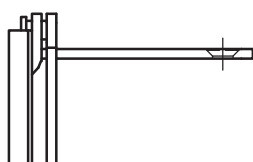



# IPA No. 62586-87 & 89 FITTING INSTRUCTIONS

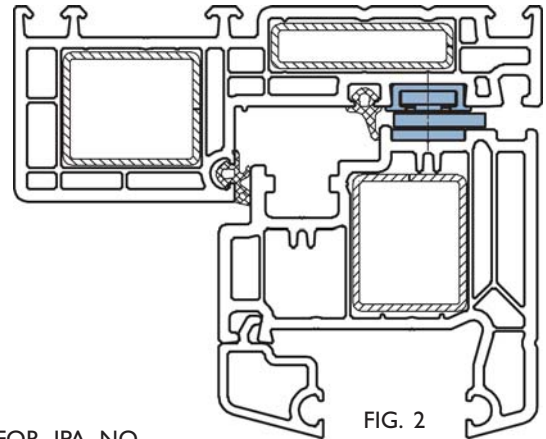
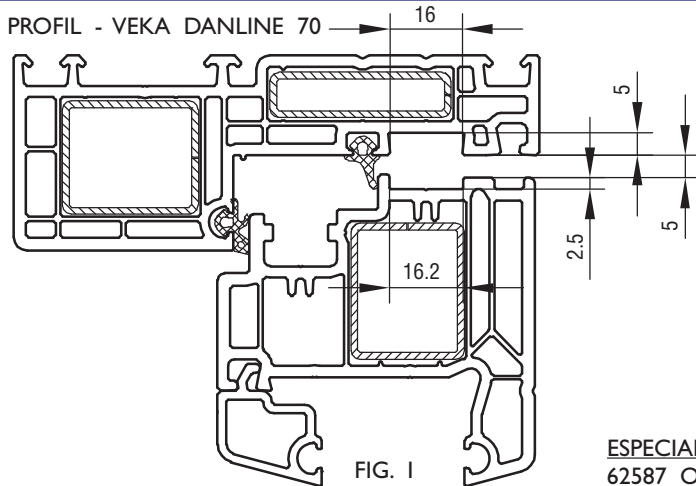

ESPECIALLY FOR IPA NO. 62587 OG 62589:  
THE SCREW IN THE TOP OF THE FRICTION ELEMENT IS ONLY TO ENSURE THAT THE GLIDING ELEMENT BELOW MOVES CORRECTLY IN THE ALUMINIUM RAIL. THEREFORE THIS SCREW MUST NOT BE ADJUSTED.

OBS! RE. IPA NO. 62587:  
FOR BIG WINDOWS (>1200 MM) WITH 3-LAYER GLASS AND NO REQUIREMENTS FOR EGRESS OPENINGS THE USE OF IPA NO. 62589 IS RECOMMENDED, AS THE VENTILATION POSITION OTHERWISE MAY BE DIFFICULT TO ACHIEVE BECAUSE OF THE OPENING GEOMETRY OF THE GEARS.

IPA NO.	62586	62587	62589
MAX. SASH WEIGHT KG	40	50	70
MAX. INSIDE FRAME HEIGHT MM	844	1344	1544
USE SCREW NO.	4.0	4.0	4.0

#### FITTING:

- CLOSE THE FITTING AND PLACE IT IN THE GROOVE OF THE SIDE FRAME. PLACE THE FITTING AGAINST THE TOP FRAME. PLACE AND FASTEN THE SCREW IN THE BOTTOM HOLE OF THE FITTING.
  - 62573: FASTEN THE STOP PLATE THROUGH THE UPPER SCREW HOLE IN THE STOP PLATE AND THROUGH THE UPPER SCREW HOLE IN THE ALURAIL. THIS ENABLES MAX. FIRE ESCAPE OPENING. USE LOWER SCREW HOLE IN STOP PLATE TO ACHIEVE A MAX. SASH LOAD OF 60 KGS. IF LOWER SCREW HOLE IS USED THE FIRE ESCAPE OPENING WILL BE REDUCED.
  - 62574: ALWAYS USE THE UPPER SCREW HOLE IN THE ALURAIL FOR FASTENING THE STOP PLATE. USE THE UPPER SCREW HOLE IN STOP PLATE FOR MAX. FIRE ESCAPE OPENING. USE THE MIDDLE SCREW HOLE IN THE STOP PLATE TO ACHIEVE A MAX. SASH LOAD OF 85 KGS. USE THE LOWER SCREW HOLE IN THE STOP PLATE TO ACHIEVE A MAX. SASH LOAD OF 100 KGS. IF MIDDLE OR LOWER SCREW HOLES IN STOP PLATE ARE USED THE FIRE ESCAPE OPENING WILL BE REDUCED.
- PUSH THE SASH INTO ITS PLACE BY INSERTING IT BETWEEN THE HINGE ARMS, GUIDED BY THE GROOVES IN THE SASH, UNTILL THE SASH HITS THE STOPS OF THE FITTING. THESE STOPS WILL GUARANTEE A 5 MM GAB BETWEEN FRAME AND SASH. FASTEN THE FITTING STARTING WITH THE SCREW IN THE STOP BRACKET.
- NOW THE FRICTION MAY BE ADJUSTED BY MEANS OF THE SCREWS IN THE SLIDES. THE BEST RESULT FOR THE WINDOW MOVEMENT IS ACHIEVED BY EQUAL FRICTION AT EITHER SIDE.
- THE SASH CAN BE ADJUSTED  $\pm 1.5$  MM UP OR DOWN. ADJUST BY USING A TORX-20 KEY TO TURN THE ECCENTRIC SCREW. BY DELIVERY THE MARK ON TH ECCENTRIC SCREW IS IN A VERTICAL POSITION INDICATING THE 0-POSITION. WHEN THE MARK IS IN HORIZONTAL POSTION IN EITHER TOP OR BOTTOM, THE FITTING IS ADJUSTED TO IT'S MAX OF  $\pm 1.5$  MM.

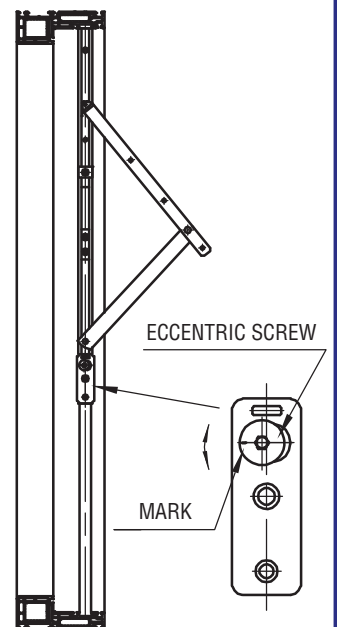

FIG. 3

#### MAINTENANCE:

THE FITTINGS ARE NOT TO BE PAINTED. TEST THE OPERATION FROM TIME TO TIME. WHEN FITTING - LUBRICATE THE PIVOT/MOVABLE METAL PARTS OF THE MECHANISM WHILE ACTIVATING REPEATEDLY. HEREAFTER LUBRICATE MINIMUM TWICE A YEAR. DO NOT LUBRICATE THE ALUMINIUM RAILS. SEE ALSO INSTRUCTIONS ON PAGE 30 - 31.



# ADJUSTABLE CANOPY STAY WITH ADJUSTABLE FRICTION

## IPA No. 62588

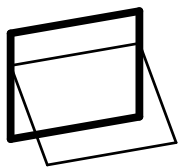

ORDERING NO.								
IPA NO.	MATERIAL	W/O SPECIFICATION	SURFACE	STANDARD PACKING IN BOXES OF 5 SETS.	A MM	B MM	SCREW	APPROX. WEIGHT KGS. / SET
	STEEL		ELECTROPLATED					
62588	1	0	21	1	19	537	4.0	0,76

- VERTICALLY ADJUSTABLE  $\pm 1.5$  MM
- ADJUSTABLE FRICTION
- CONCEALED FITTINGS
- ANODIZED ALUMINIUM RAILS
- THE MOVEMENT GEOMETRY ENSURES  
MAXIMUM SEALING

FIRE-ESCAPE OPENING:  
PLEASE SEE [WWW.IPAFITTINGS.COM/RESCUE](http://WWW.IPAFITTINGS.COM/RESCUE)



# IPA No. 62588 FITTING INSTRUCTIONS

PROFIL - VEKA DANLINE 70

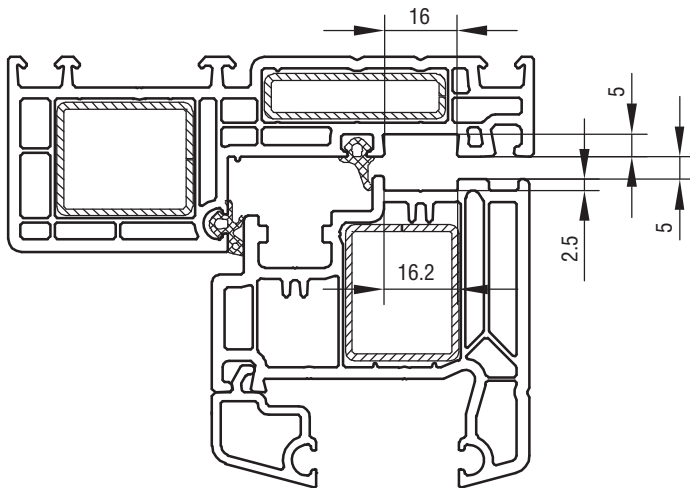

FIG. 1

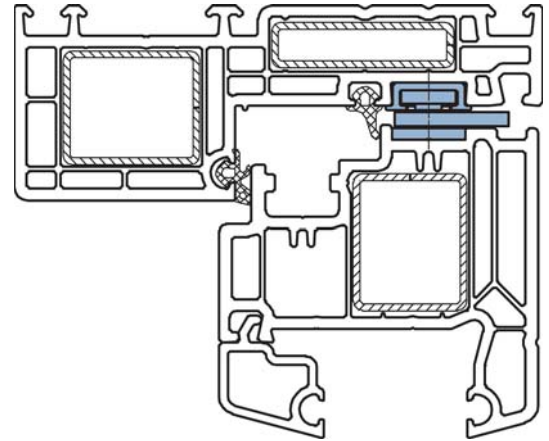

FIG. 2

IPA NO.	62588
MAX. SASH WEIGHT KG	50
MAX. INSIDE FRAME HEIGHT MM	1144
USE SCREW NO.	4.0

#### FITTING:

1. CLOSE THE FITTING AND PLACE IT IN THE GROOVE OF THE SIDE FRAME. PLACE THE FITTING AGAINST THE TOP FRAME. PLACE AND FASTEN THE SCREW IN THE BOTTOM HOLE OF THE FITTING. OPEN THE FITTING AND FASTEN THE REMAINING SCREWS.
2. PUSH THE SASH INTO ITS PLACE BY INSERTING IT BETWEEN THE FITTINGS, GUIDED BY THE GROOVES IN THE SASH, TILL THE SASH HITS THE STOPS OF THE FITTING. THESE STOPS WILL GUARANTEE A 5 MM GAB BETWEEN FRAME AND SASH. FASTEN THE FITTING STARTING WITH THE SCREW IN THE STOP BRACKET
3. NOW THE FRICTION MAY BE ADJUSTED BY MEANS OF THE SCREWS IN THE SLIDES. WHEN ADJUSTING LET THE TOP GLIDER MOVE DOWN TO THE STOP. THE BEST RESULT FOR THE WINDOW MOVEMENT IS ACHIEVED BY EQUAL FRICTION AT EITHER SIDE.
4. THE SASH CAN BE ADJUSTED  $\pm 1.5$  MM UP OR DOWN. ADJUST BY USING A TORX-20 KEY TO TURN THE ECCENTRIC SCREW. BY DELIVERY THE MARK ON THE ECCENTRIC SCREW IS IN A VERTICAL POSITION INDICATING THE 0-POSITION. WHEN THE MARK IS IN HORIZONTAL POSITION IN EITHER TOP OR BOTTOM, THE FITTING IS ADJUSTED TO IT'S MAX OF  $\pm 1.5$  MM.

#### MAINTENANCE:

THE FITTINGS ARE NOT TO BE PAINTED. TEST THE OPERATION FROM TIME TO TIME. WHEN FITTING - LUBRICATE THE PIVOT/MOVABLE METAL PARTS OF THE MECHANISM WHILE ACTIVATING REPEATEDLY. HEREAFTER LUBRICATE MINIMUM TWICE A YEAR. DO NOT LUBRICATE THE ALUMINIUM RAILS. SEE ALSO INSTRUCTIONS ON PAGE 30 - 31.

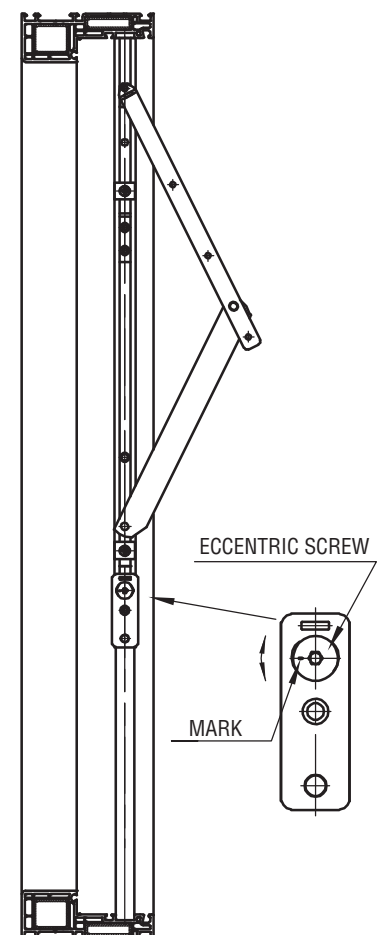
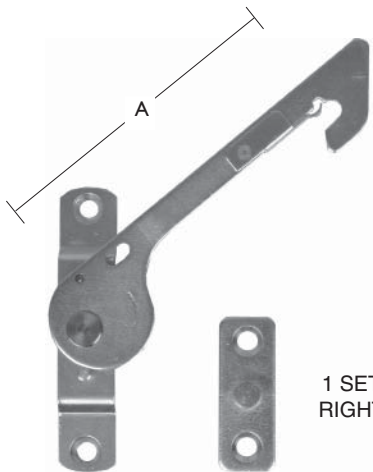
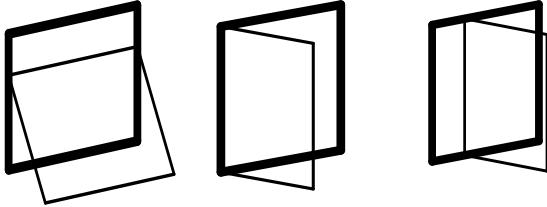

FIG. 3



# SAFETY CATCH

## IPA No. 62536



ORDERING NO.								
IPA NO.	MATERIAL			SURFACE	STANDARDPACKING IN BOXES OF 5 SETS	A MM	SCREW	APPROX. WEIGHT KG / SET
	STEEL	LEFT	RIGHT	ELECTROPLATED				
<b>62536</b>	<b>1</b>	<b>7</b>	<b>8</b>	<b>21</b>	<b>1</b>	92	4.0	0.06



# IPA No. 62536 FITTING INSTRUCTIONS

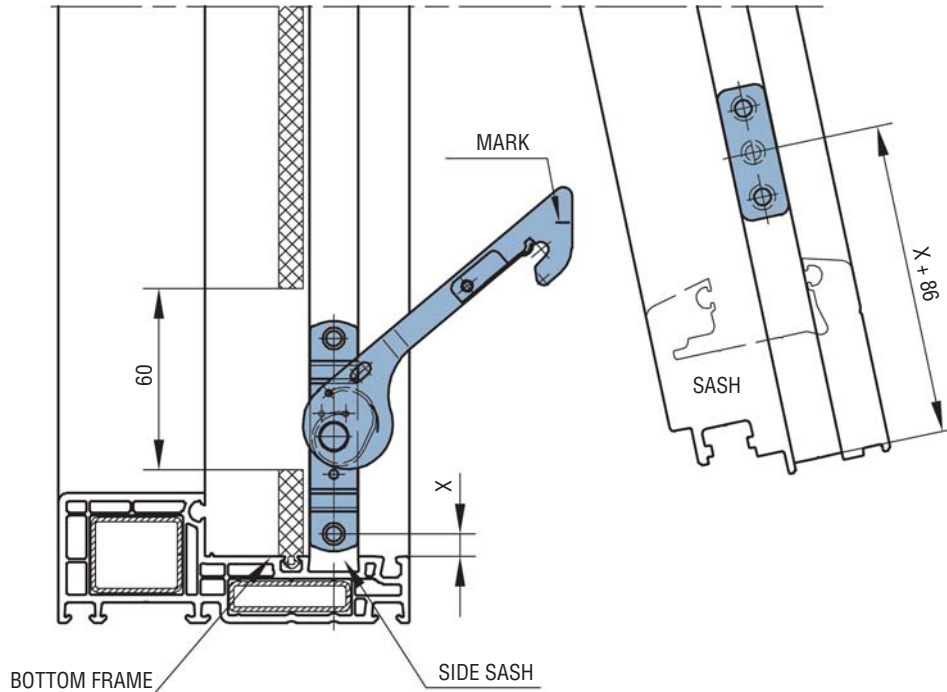

FIG. 1  
RIGHT HAND ILLUSTRATION

THE FITTING CAN BE USED ON BOTH TOPHUNG/TOPGUIDED AS WELL AS SIDEHUNG/SIDEGUIDED WINDOWS. ON TOPHUNG/TOPGUIDED WINDOWS THE RESTRICTOR IS PLACED IN THE BOTTOM OF THE SIDE FRAME AND THE RECEIVER IS PLACED IN THE BOTTOM OF THE SIDE SASH. ON THE SIDEHUNG/SIDEGUIDED WINDOWS THE RESTRICTOR IS PLACED IN TOP/BOTTOM FRAME ON THE OPPOSITE SIDE OF THE HINGES AND THE RECEIVER IS PLACED IN THE TOP/BOTTOM SASH OPPOSITE THE HINGES.

TO ACCOMMODATE THE RESTRICTOR IT WILL BE NECESSARY TO REMOVE 60 MM OF THE WEATHER STRIP AS SHOWN ON FIG. 1.

X-DIMENSION IS OPTIONAL. ON TOPHUNG/TOPGUIDED WINDOWS X MUST MINIMUM BE 7 MM. BY USING LARGER X-DIMENSION THE VENTILATION OPENING WILL BE EXTENDED.

**IMPORTANT:** THE RECEIVER MUST BE MOUNTED SO THAT IT HITS THE MARK ON THE RESTRICTOR ARM WHEN THE WINDOW IS CLOSED. SEE FIG. 1

#### OPERATING INSTRUCTIONS:

1. OPEN THE WINDOW UNTIL THE RESTRICTOR ENGAGES.
2. PULL THE SASH APPROXIMATELY 20 MM BACKWARDS.
3. PRESS THE RESTRICTOR OUTWARDS AS YOU OPEN THE WINDOW.
4. WHEN THE WINDOW IS CLOSED THE RESTRICTOR RE-ENGAGES AUTOMATICALLY.

USE SCREW NO. 4.0

#### MAINTENANCE:

THE FITTINGS ARE NOT TO BE PAINTED. TEST THE OPERATION FROM TIME TO TIME. WHEN FITTING - LUBRICATE THE PIVOT/MOVABLE METAL PARTS OF THE MECHANISM WHILE ACTIVATING REPEATEDLY. HEREAFTER LUBRICATE MINIMUM TWICE A YEAR. DO NOT LUBRICATE THE ALUMINIUM RAILS. SEE ALSO INSTRUCTIONS ON PAGE 30 - 31.

PROFILE - VEKA DANLINE 70

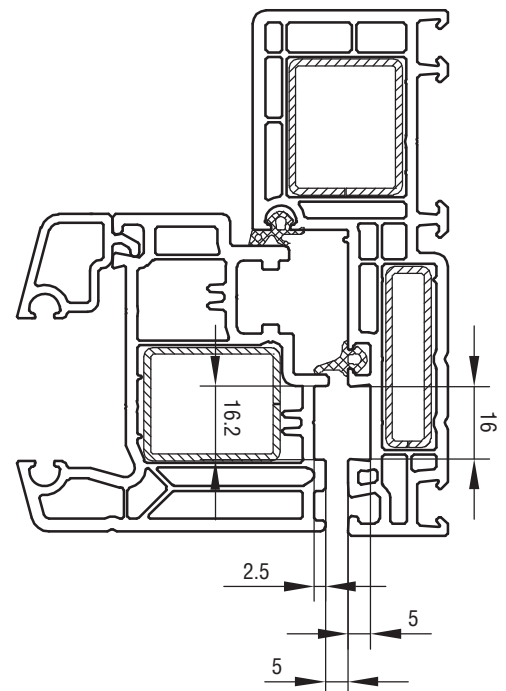
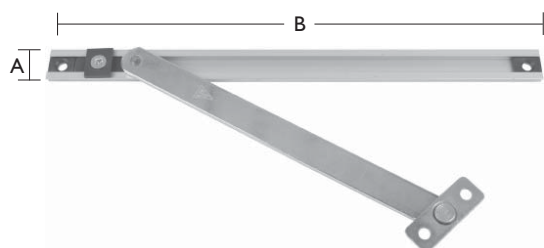
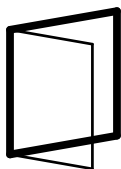

FIG. 2



# FRICITION STAY for windows

## IPA No. 62527



ORDERING NO.									
IPA NO.	MATERIAL	SURFACE		STANDARD PACKING IN BOXES OF 25 PCS.	A MM	B MM	MATERIAL MM	SCREW	APPROX. WEIGHT KG / PC.
	STEEL	W/O SPECIFICATION	ELECTROPLATED						
<b>62527</b>	<b>1</b>	<b>0</b>	<b>21</b>	<b>1</b>	19	274	17X3	4.0	0.14

- CONCEALED FITTING
- OPENS UP TILL 100°
- FRICTION IN ALL POSITIONS
- ADJUSTABLE FRICTION
- ANODIZED ALUMINIUM RAIL



## IPA No. 62527

# FITTING INSTRUCTIONS

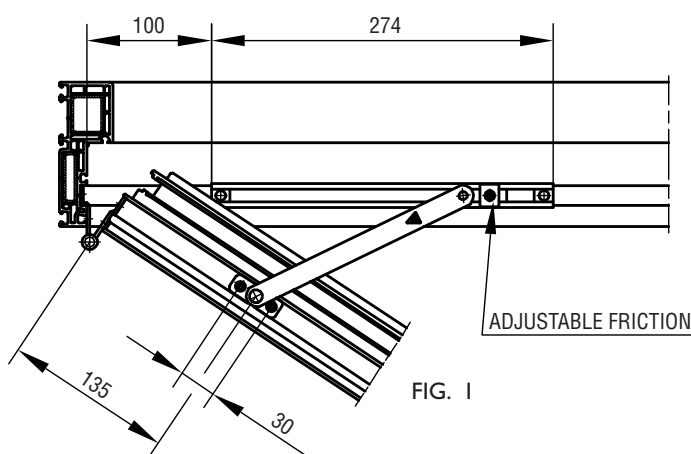

PROFILE - VEKA DANLINE 70

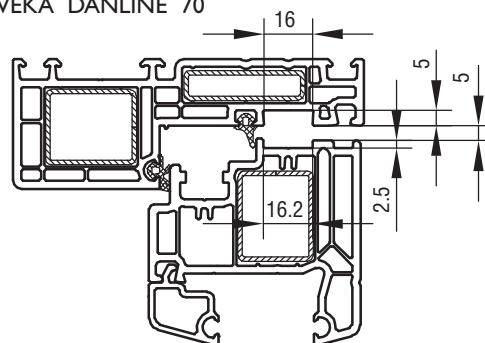

FIG. 2

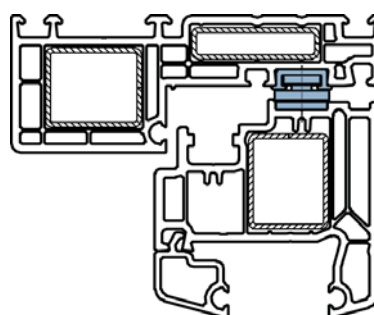

FIG. 3

### MAINTENANCE:

THE FITTING ARE NOT TO BE PAINTED. TEST THE OPERATION FROM TIME TO TIME. WHEN MOUNTING - LUBRICATE THE PIVOT/MOVABLE METAL PARTS OF THE MECHANISM WHILE ACTIVATING REPEATEDLY. HEREAFTER LUBRICATE MINIMUM TWICE A YEAR. DO NOT LUBRICATE THE ALUMINIUM RAIL. SEE ALSO INSTRUCTIONS ON PAGE 30 - 31.



# FRICITION STAY for doors

## IPA No. 63511

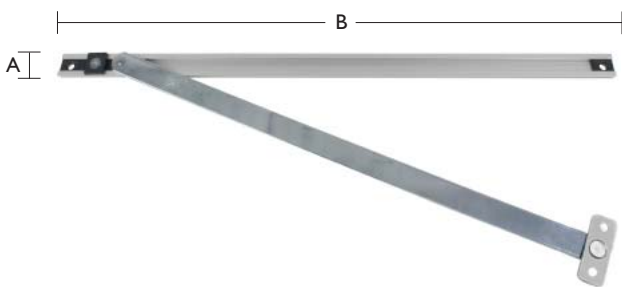
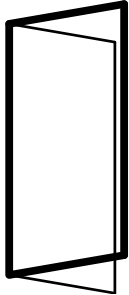

ORDERING NO.		MATERIAL		SURFACE		STANDARD PACKING IN BOXES OF 10 PCS.		APPROX. WEIGHT KG / PCS.	
IPA NO.	STEEL	W/O SPECIFICATIONS	ELECTROPLATED	A MM	B MM	MATERIAL MM	SCREW		
63511	1	0	21	1	19	414	17X3	4.0	0.22

- CONCEALED FITTING
- OPENS UP TILL 100°
- FRICTION IN ALL POSITIONS
- ADJUSTABLE FRICTION
- ANODIZED ALUMINIUM RAIL



# IPA No. 63511 FITTING INSTRUCTIONS

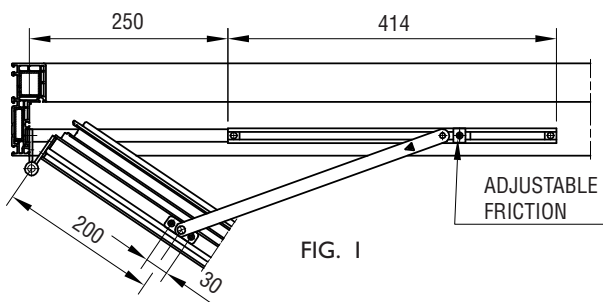

FIG. 1

PROFILE - VEKA DANLINE 70

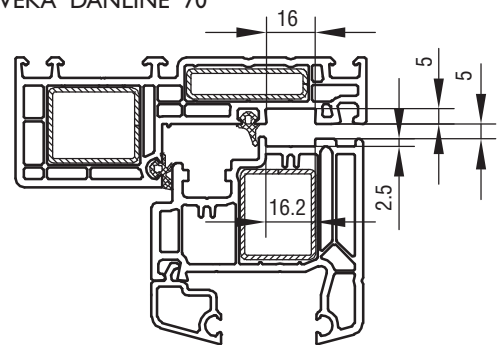

FIG. 2

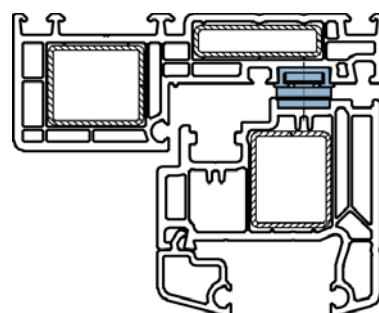

FIG. 3

**MAINTENANCE:**

THE FITTING ARE NOT TO BE PAINTED. TEST THE OPERATION FROM TIME TO TIME. WHEN MOUNTING - LUBRICATE THE PIVOT/MOVABLE METAL PARTS OF THE MECHANISM WHILE ACTIVATING REPEATEDLY. HEREAFTER LUBRICATE MINIMUM TWICE A YEAR. DO NOT LUBRICATE THE ALUMINIUM RAIL. SEE ALSO INSTRUCTIONS ON PAGE 30 - 31.





# ACCESSORIES

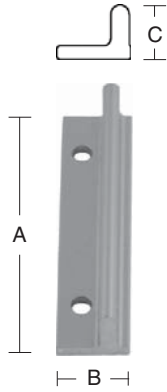

SUPPORT FITTING  
IPA No. 62222

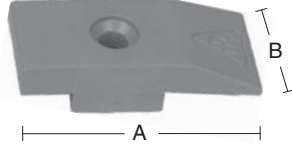

GUIDE BLOCK  
IPA No. 63230

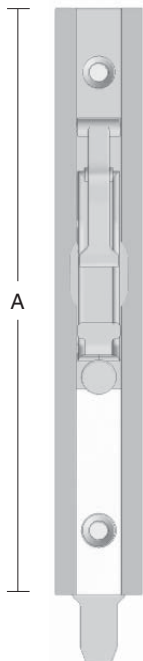

IPA No.s 63508-09

## SUPPORT FITTING AND GUIDE BLOCK

ORDERING NO.													
IPA NO.	MATERIAL		W/O SPECIFICATION	SURFACE		STANDARD PACKING IN BOXES OF 20 PCS.	STANDARD PACKING IN BOXES OF 25 PCS.	A MM	B MM	C MM	SCREW HOLES MM	SCREW	APPROX. WEIGHT KG / PC.
	ALUMINIUM	PLASTIC		ANODIZED	GREY								
<b>62222</b>	<b>0</b>	<b>-</b>	<b>0</b>	<b>00</b>	<b>-</b>	<b>-</b>	<b>1</b>	70	16	12	5.0	-	0.05
<b>63230</b>	<b>-</b>	<b>9</b>	<b>0</b>	<b>-</b>	<b>54</b>	<b>1</b>	<b>-</b>	42	20	10	-	4.0	0.04

## FLUSH BOLTS

ORDERING NO.												
IPA NO.	MATERIAL		SURFACE	STANDARD PACKING IN BOXES OF 10 PCS.	A MM	B MM	THICKNESS MM	BOLT MM	LENGTH BOLT MM	SCREW	APPROX. WEIGHT KG / PC.	
	STEEL	SQUARE EDGES										ELECTROPLATED
<b>63508</b>	<b>1</b>	<b>5</b>	<b>21</b>	<b>1</b>	128	19	6	8.5X2.5	15	3.5	0.04	
<b>63509</b>	<b>1</b>	<b>5</b>	<b>21</b>	<b>1</b>	128	19	6	8.5X2.5	20	3.5	0.04	



# CASEMENT HOOKS, HOOK CATCH & CASEMENT FASTENERS

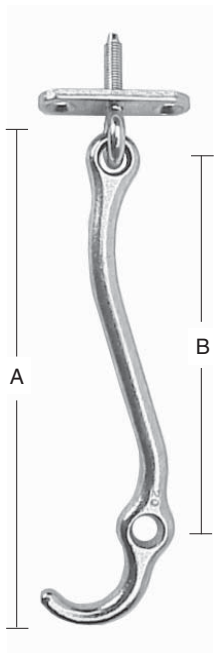

**21371**

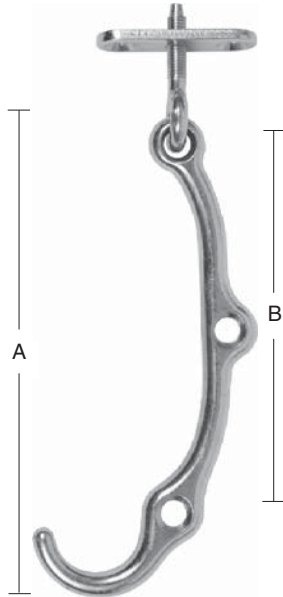

**21379**

ORDERING NO.											
IPA NO.	MATERIAL	W/O SPECIFICATION	SURFACE			STANDARD PACKING IN BOXES OF 50 PIECES	INDUSTRY PACKING IN BOXES OF 250 PIECES	A MM	B MM	HOLE FOR PIN MM	APPROX. WEIGHT KG / 100 PIECES
			ELECTROPLATED / WHITE	ELECTROPLATED	ELECTROPLATED YELLOW						
<b>21371</b>	<b>0</b>	<b>0</b>	<b>06</b>	<b>21</b>	<b>25</b>	<b>-</b>	<b>2</b>	130	95	6	6,0
<b>21379</b>	<b>0</b>	<b>0</b>	<b>-</b>	<b>21</b>	<b>25</b>	<b>1</b>	<b>-</b>	120	93	6	5,6
	<b>0</b>	<b>0</b>	<b>06</b>	<b>21</b>	<b>25</b>	<b>-</b>	<b>2</b>				

ATTENTION: IPA NO. 21379 IN POWDER PAINTED VERSIONS CAN ONLY BE USED TOGETHER WITH IPA NO. 21382.

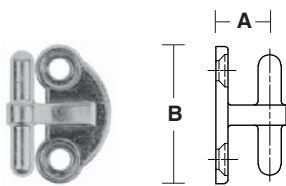

**21382**

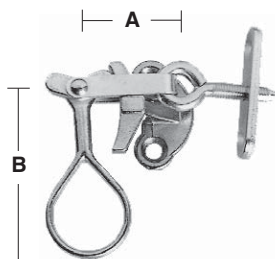

**21396**

ORDERING NO.													
IPA NO.	MATERIAL	W/O SPECIFICATION	SURFACE			STANDARD PACKING IN BOXES OF 50 PIECES	INDUSTRY PACKING IN BOXES OF 250 PIECES	INDUSTRY PACKING IN BOXES OF 500 PIECES	A MM	B MM	PIN MM	SCREW	APPROX. WEIGHT KG / 100 PIECES
			ELECTROPLATED / WHITE	ELECTROPLATED	ELECTROPLATED YELLOW								
<b>21382</b>	<b>1</b>	<b>0</b>	<b>-</b>	<b>21</b>	<b>25</b>	<b>1</b>	<b>-</b>	<b>-</b>	13,3	34	5,6	3,5	0,75
	<b>1</b>	<b>0</b>	<b>06</b>	<b>-</b>	<b>25</b>	<b>-</b>	<b>2</b>	<b>-</b>					
<b>21396</b>	<b>1</b>	<b>0</b>	<b>06</b>	<b>21</b>	<b>25</b>	<b>-</b>	<b>-</b>	<b>2</b>	24	50	-	3,5	5,0



# FITTING INSTRUCTIONS

## IPA NO. 21371 + 21379 + 21382

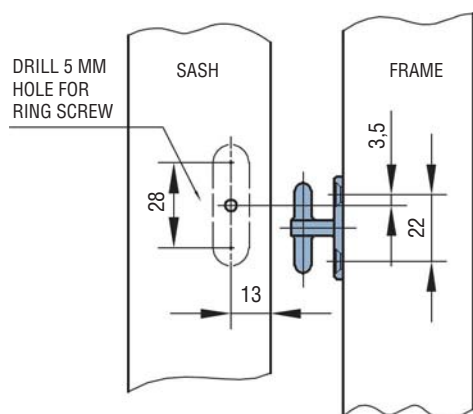

FIG. 1  
IPA NO. 21382

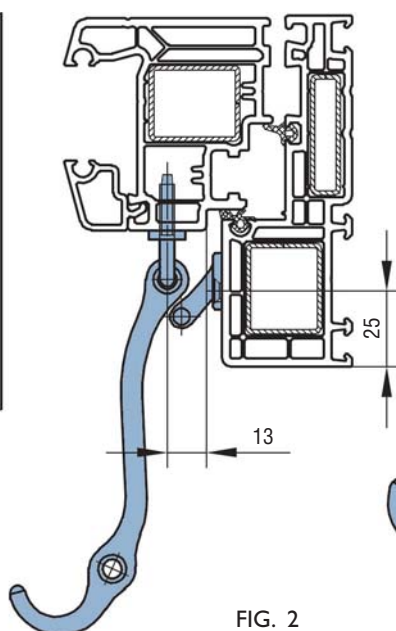

FIG. 2  
IPA NO. 21371 WITH 21382

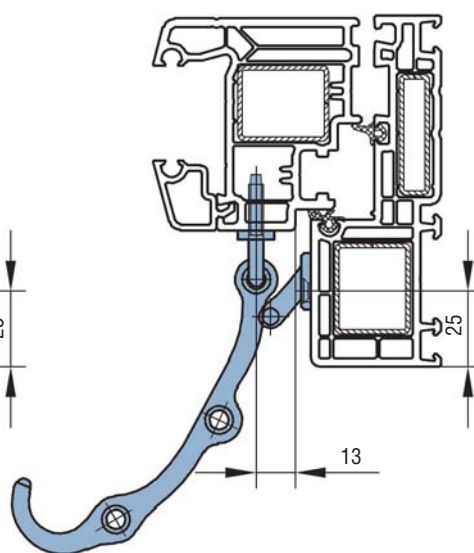
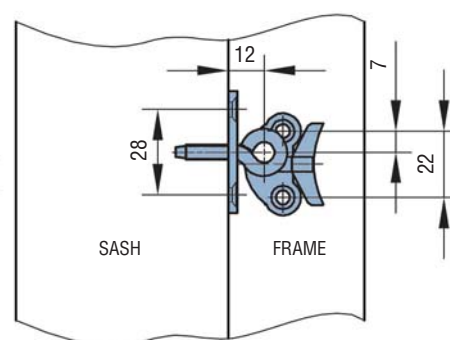
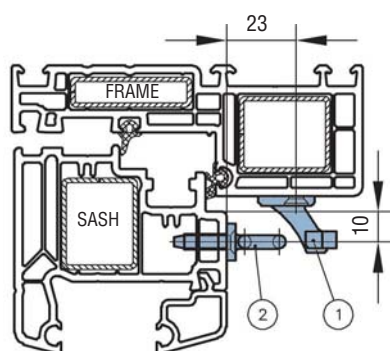
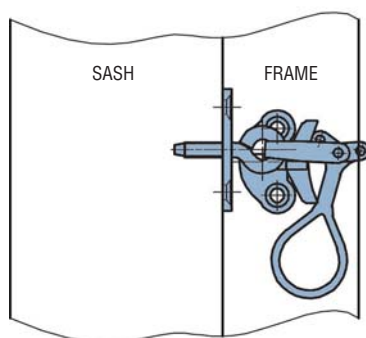

FIG. 3  
IPA NO. 21379 WITH 21382

## IPA NO. 21396



### MOUNTING:

1. MOUNT THE RECEIVER ① IN THE WANTED HEIGHT ON THE SIDEFAME.
2. FOR CASEMENT FASTENERS WITH SCREW PLATE ② MEASURE PRECISELY ON THE SASH AND ROUGH-BORE FOR THE RING SCREW. MARK UP THE 2 SCREW HOLES ON THE SCREW PLATE AND FASTEN THE CASEMENT FASTENER..



# ESPAGNOLETES, RECEIVERS & HANDLES

## ESPAGNOLETES WITH 12 MM BOLTS AND 25 MM BACKSET

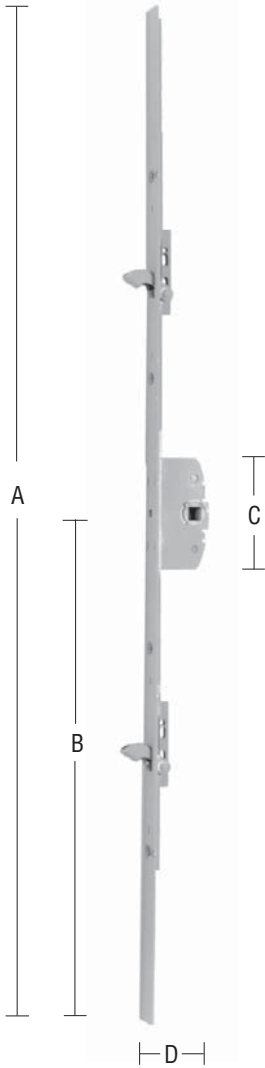

**23701-10**

ORDERING NO.													
IPA NO.	MATERIAL	SAUARE EDGES	SURFACE	STANDARD PACKING IN BOXES OF 10 PIECES	A MM	B MM	PIN MM	C MM	D MM	FACEPLATE MM	THICKNESS PLATE MM	SCREW	APPROX. WEIGHT KGS / EACH
	STEEL		ELECTROPLATED										
23701	1	6	21	1	600	300	8	66	34	16/17	2,5	4,0	0,30
23702	1	6	21	1	720	360	8	66	34	16/17	2,5	4,0	0,35
23703	1	6	21	1	820	410	8	66	34	16/17	2,5	4,0	0,40
23704	1	6	21	1	920	460	8	66	34	16/17	2,5	4,0	0,45
23705	1	6	21	1	1020	510	8	66	34	16/17	2,5	4,0	0,50
23706	1	6	21	1	1120	560	8	66	34	16/17	2,5	4,0	0,55
23707	1	6	21	1	1220	610	8	66	34	16/17	2,5	4,0	0,60
23708	1	6	21	1	1320	660	8	66	34	16/17	2,5	4,0	0,65
23709	1	6	21	1	1420	710	8	66	34	16/17	2,5	4,0	0,70
23710	1	6	21	1	1400	700	8	66	34	16/17	2,5	4,0	0,69

## RECEIVER



RECEIVER \*  
IPA NO. 23269

ORDERING NO.										
IPA NO.	MATERIAL	W/O SPECIFICATION	SURFACE	STANDARD PACKING IN BOXES OF 20 PIECES	INDUSTRY PACKING IN BOXES OF 100 PIECES	A MM	B MM	MATERIAL MM	SCREW	APPROX. WEIGHT KGS / 100 PIECES
	STEEL		ELECTROPLATED							
23269	1	0	21	1	2	46	25	7	4,0	3,0

## HANDLES



**23228-29**  
RIGHT

ORDERING NO.											
IPA NO.	MATERIAL	LEFT	RIGHT	SURFACE		STANDARD PACKING IN BOXES OF 10 PIECES	PIN MM	DISTANCE BETWEEN SCREWHOLE MM	LENGTH OF PIN MM	HOLES FOR SCREWS MM	APPROX. WEIGHT KGS / EACH
	ALLOY			DULL CROME	CROME						
23228	0	7	8	80	81	1	8	42	43	5	0,15
23229	0	7	8	80	81	1	8	42	43	5	0,15



# FITTING INSTRUCTIONS

IPA NO.	L MM	A MM	B MM	D MM
23701	600	300	140	12
23702	720	360	140	12
23703	820	410	190	12
23704	920	460	240	12
23705	1020	510	290	12
23706	1120	560	340	12
23707	1220	610	390	12
23708	1320	660	440	12
23709	1420	710	490	12
23710	1400	700	540	12

FIG. 1

### SHORTENING POSSIBILITIES:

130 MM AT THE TOP WITH SIDE BOLTS OUT.  
130 MM AT THE BOTTOM WITH SIDE BOLTS IN.

IPA NO. 23701 HAS SMALLER SHORTENING POSSIBILITIES.

PLEASE NOTE THE SMALL CUT OUTS IN THE WEATHERSTRIP AND IN THE SASH. THIS IS TO MAKE ROOM FOR THE RECEIVER.

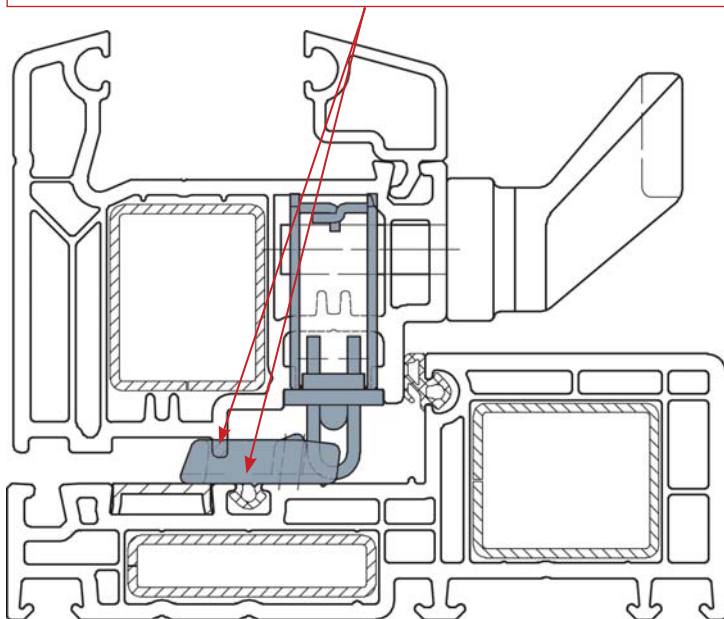

FIG. 2

VEKA DANLINE 70 PROFILE MOUNTED WITH ESPAGNOLETTE  
IPA NO. 23701-10 AND RECEIVER IPA NO. 23269.

### MAINTENANCE:

THE FITTINGS ARE NOT TO BE PAINTED. TEST THE OPERATION FROM TIME TO TIME. WHEN MOUNTING - LUBRICATE THE PIVOT/MOVABLE METAL PARTS OF THE MECHANISM WHILE ACTIVATING REPEATEDLY. HEREAFTER LUBRICATE MINIMUM TWICE A YEAR. SEE ALSO INSTRUCTIONS ON PAGE 30 - 31.

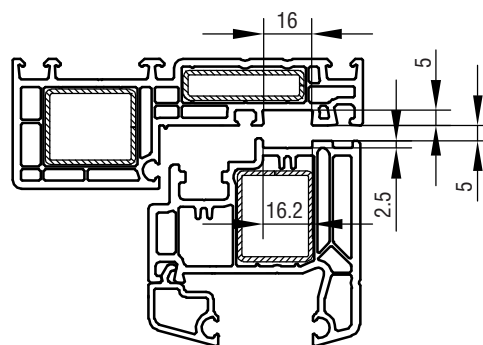
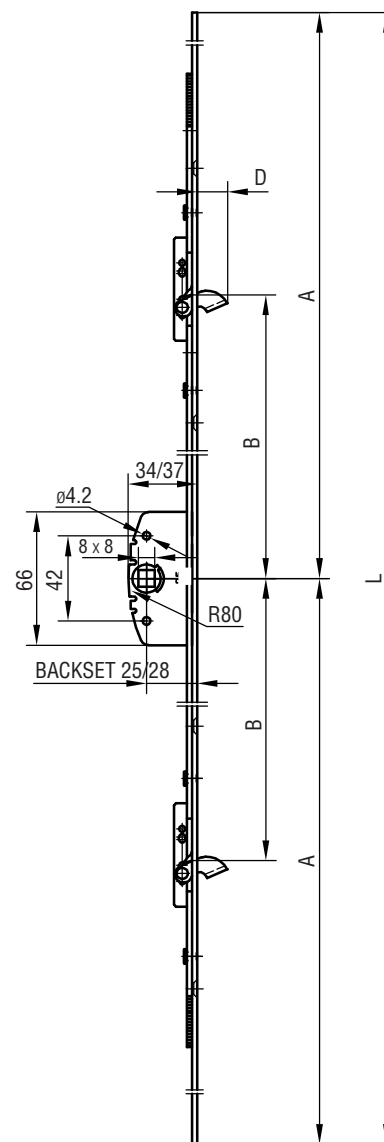

FIG. 2

FACE PLATE: 16/17 MM

USE SCREW NO. 4.



IPA NO.s 23701-24

FIG. 3



# MAINTENANCE LUBRICATION INSTRUCTIONS

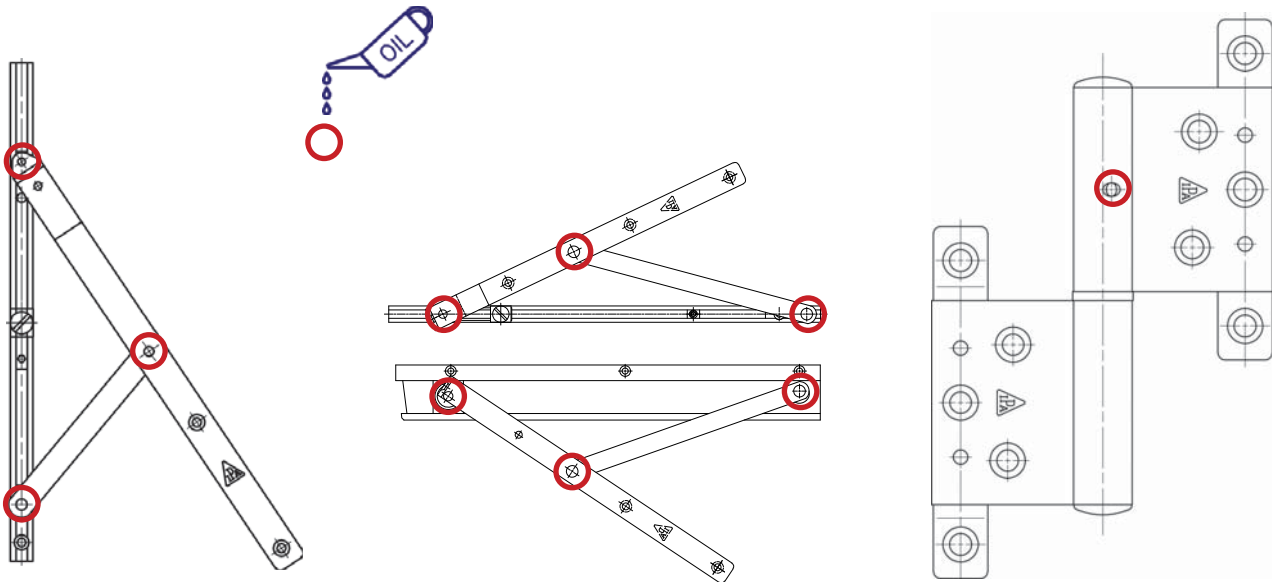

**GENERALLY** all parts of a building have to be looked after and maintained from time to time. This of course also applies for fittings in windows and doors.

How often fittings in windows and doors should be maintained depends to a large extent on how they are used, how often they are operated, and not least on the environment the fittings are exposed to.

Corrosion may also be caused by other factors, such as corrosive liquids, air pollution etc. Special attention should be given to fittings used in windows and doors in urban and industrial areas or other areas with a high traffic intensity as well as coastal areas. Fittings in such environments should be checked and greased more often than fittings used in areas with less corrosive effects.

**HINGES AND FITTINGS** should be lubricated when necessary, or at the minimum twice a year.

**SLIDING ELEMENTS AS WELL AS ALL ALURAILS** with sliding surfaces are to be kept clean and free from dust and dirt to ensure a smooth sliding function. Stearin wax or a clean lubricating film (but no oil and no grease!) can be applied onto the aluminium rails.

**ESPAGNOLETTES AND OTHER LOCKING FITTINGS** should be greased or lubricated with acid free grease or acid free oil on spray. The grease/oil should be applied into the mechanism box as well as on the joints of the side bolts, the roller bolts, or the mushroom head bolts while activating the mechanism repeatedly. Grease or lubricate when necessary or at the minimum twice a year.

Continues.....



# MAINTENANCE LUBRICATION INSTRUCTIONS

**BRASS** will sooner or later get some discoloration in a brownish tone depending on the environment in which it is placed. The original brass surface can be maintained by polishing from time to time.

**STAINLESS STEEL** can get some discoloration, although this rarely happens. Different chemical influences like acid fumes, contamination from wood preservation treatments, or air pollution may cause discoloration of the metal, sometimes to a reddish tone which could look like rust. Thin discoloration can be removed just by using common cleaner or polish.

**PAINTED FITTINGS** will from time to time need repainting. Before painting all parts should be cleaned carefully. When choosing type of paint and when applying the paint remember to follow the instructions from the paint manufacturer very carefully.

When painting a wooden window in a house, it is a good idea also to paint the visible parts of the fittings (please note: No alurails nor sliding parts should ever be painted!). The painting of the fitting will minimize corrosion and add to the lifetime of the fitting. Always make sure that the proper function of a fitting is not affected by the painting.

**ANODIZED ALUMINIUM** should be cleaned from time to time, depending on the surroundings in which it is placed. Cleaning of the surface with a cloth or sponge is recommended. Eventually a neutral solvent can be used. Emery cloth, steel wool, sodium carbonate, and other cleansers or abrasives containing alkalies or acid should never be used.

**ON THE WINDOW AND DOOR FACTORY SITE** all fittings should be lubricated or greased before shipment. Hinges should be lubricated with acidfree oil while activating repeatedly, an acidfree grease can also be used. When using grease it should be applied directly onto the pin of the hinges. It may be necessary to dismantle the sash before greasing. Especially hinges with a brass pin should be greased.

When mounting fittings, please make sure that the tools do not damage the original surface treatment. When original surface has been damaged make sure that remedial take place as soon as possible.

**WHEN IN DOUBT PLEASE CONTACT YOUR LOCAL SUPPLIER OR A/S J. PETERSENS  
BESLAGFABRIK.**



## **A/S J. PETERSENS BESLAGFABRIK**

---

JACOB PETERSENSVEJ 9, DK-9240 NIBE  
[www.ipafittings.com](http://www.ipafittings.com)

TEL.: (+45) 98 35 15 00  
[ipa@ipafittings.com](mailto:ipa@ipafittings.com)